

Model 266DDH Differential  
Model 266HDH Gauge  
Model 266NDH Absolute

## 2600T Series Pressure Transmitters

Engineered solutions for all applications



**Base accuracy**

- from 0.06 % of calibrated span

**Reliable sensing system coupled with very latest digital technologies**

- provides large turn down ratio up to 60:1

**Comprehensive sensor choice**

- optimize in-use total performance and stability

**Flexible configuration facilities**

- provided locally via local LCD keypad

**New TTG (Through-The-Glass) keypad technology**

- allows quick and easy local configuration without opening the cover, even in explosion proof environments

**IEC 61508 certification**

- for SIL2 (1001) and SIL3 (1002) applications

**PED compliance to sound engineering practice (SEP)**

# Model 266DDH Differential

## Model 266HDH Gauge

## Model 266NDH Absolute

### General description

Model 266xx detailed in this data sheet apply for those transmitters which include on high pressure measuring side, a direct mount seal which is integral to the transducer by a short capillary connection inside a protective rigid tube. This construction forms a standalone single assembly suitable to be mounted to the process by the seal mounting facilities. By properly selecting the high and low pressure side variant in the ordering codes model 266DDH can be in the following versions:

- one direct mount seal and one flange for process connection, direct 1/4 – 18 NPT or 1/2 – 14 NPT through adapter; this allows also to connect the other leg (wet or dry) for differential measurement.
- one direct mount seal and one remote seal with capillary; the two seals allow again a differential measurement and must be selected of same type/size.

Model 266HDH and 266NDH have the direct mount seal on the positive side, respectively with the reference at atmospheric or vacuum pressure, for gauge or absolute measurements.

Refer to S26 seals data sheet for additional data and details relevant to seal element. The following table list the types of standard seal which can be mounted with 266xD transmitters (the mnemonic is used as reference in the compatibility table).

Seal model	Seal type	Seal diaphragm size (thickness)	Mnemonic
S26FA S26FE S26RA S26RE	Flanged flush diaphragm (ASME and EN standards; fixed and rotating flange)	2 in. / DN 50	P2
		3 in. / DN 80	P3
		4 in. / DN 100	P3
		2 in. / DN 50 (low)	F2
		3 in. / DN 80 (low)	F3
S26RE	Flanged extended diaphragm (ASME and EN standards; only rotating flange S26RA and S26RE)	4 in. / DN 100 (low)	F3
		2 in. / DN 50	E2
		3 in. / DN 80	E3
S26RJ	Flanged flush diaphragm (JIS standards; only rotating flange)	4 in. / DN 100	P3
		A 50	P2
		A 80	P3
S26RR	Flanged flush diaphragm (Ring Joint ASME standards; rotating flange)	A 100	P3
		1.5 in.	P1.5
		2 in.	P2
S26TT	Threaded off-line flanged	3 in.	P3
S26MA S26ME	Off-line flanged (ASME and EN standards)	2 1/2 in.	T 2.5
S26SS	Beverage	2 1/2 in.	T 2.5
	Union nut, Triclamp, Cherry Burrel, Sanitary, Aseptic	1 1/2 in.	K 1.5
		2 in. / F50	S2
S26VN	Saddle and Socket	3 in. / F80	S3
		4 in.	S3
S26JN	In-line type (ONLY DIRECT MOUNT WITH 266HDH / 266NDH)	2 1/2 in.	P1.5
		1 in.	J1
		1 1/2 in.	J1.5
		2 in.	J2
S26KN	Pulp & Paper application specific (ONLY DIRECT MOUNT WITH 266HDH / 266NDH)	3 in.	J3
		1 in. ball valve (NOT AVAILABLE WITH 266NDH)	Y1
		1 in. (gasketed, NPT, G 1)	M1
		1 1/2 in. (gasketed)	M1.5
		1 1/2 in. (NPT - G 1 1/2)	M1.5A
	1 1/2 in. (M44 thread)	M1.5B	

## Functional Specifications

### Range and span limits

Sensor Code	Upper Range Limit (URL)	Lower Range Limit (LRL)			Minimum span		Compatibility (allowed seal)	
		266DDH differential	266DDH gauge	266HDH gauge 266NDH absolute		266HDH 266NDH with S26KN	Direct mount seal only (different from S26KN)	Direct mount plus remote seal for 266DDH (max length in m)
E	16 kPa 160 mbar 64 inH2O	-16 kPa -160 mbar -64 inH2O	-16 kPa -160 mbar -64 inH2O		0.8 kPa 8 mbar 3.2 inH2O		P2, P3, F2, F3, E3, T2.5 S3	P3 (3), F2 (2), F3 (2) E3 (2), T2.5 (2), S3 (3)
F	40 kPa 400 mbar 160 inH2O	-40 kPa -400 mbar -160 inH2O	-40 kPa -400 mbar -160 inH2O		0.67 kPa 6.7 mbar 2.67 inH2O		P2, P3, F2, F3 E3, T2.5, S2, S3	P2 (2), P3 (5), F2 (3), F3 (6), E3 (3), T2.5 (3), S3 (4)
G	65 kPa 650 mbar 260 inH2O	-65 kPa -650 mbar -260 inH2O	-65 kPa -650 mbar -260 inH2O	-65 kPa (Δ) -650 kPa (Δ) -260 inH2O (Δ)	1.1 kPa 11 mbar 4.35 inH2O	2.2 kPa 22 mbar 8.7 inH2O	P2, P3, F2, F3 E2, E3, T2.5, S2, S3	P2 (2), P3 (5), F2 (3), F3 (6), E3 (3), T2.5 (3), S3 (4)
H	160 kPa 1600 mbar 642 inH2O	-160 kPa -1600 mbar -642 inH2O	0.07 kPa abs (§) 0.7 mbar abs (§) 0.5 mmHg (§)	0.07 kPa abs (§) 0.7 mbar abs (§) 0.5 mmHg (§)	2.67 kPa 26.7 mbar 10.7 inH2O	5.34 kPa 53.4 mbar 21.4 inH2O	P1.5, P2, P3, F2, F3, E2, E3, T2.5, K1.5, S2, S3	P1.5 (3), P2 (5), P3 (10), F2 (8), F3 (10), E2 (4), E3 (8), T2.5 (8), S2 (3), S3 (8)
M	600 kPa 6 bar 87 psi	-600 kPa -6 bar -87 psi	0.07 kPa abs (§) 0.7 mbar abs (§) 0.5 mmHg (§)	0.07 kPa abs (§) 0.7 mbar abs (§) 0.5 mmHg (§)	10 kPa 0.1 bar 1.45 psi	20 kPa 0.2 bar 2.9 psi	P1.5, P2, P3, F2, F3, E2, E3, T2.5, K1.5, S2, S3, Jx (all)	P1.5 (5), P2 (8), P3 (10), F2 (12), F3 (16), E2 (6), E3 (10), T2.5 (8), S2 (6), S3 (8)
P	2400 kPa 24 bar 348 psi	-2400 kPa -24 bar -348 psi	0.07 kPa abs (§) 0.7 mbar abs (§) 0.5 mmHg (§)	0.07 kPa abs (§) 0.7 mbar abs (§) 0.5 mmHg (§)	40 kPa 0.4 bar 5.8 psi	80 kPa 0.8 bar 11.6 psi	P1.5, P2, P3, F2, F3, E2, E3, T2.5, K1.5, S2, S3, Jx (all)	P1.5 (5), P2 (8), P3 (10), F2 (16), F3 (16), E2 (6), E3 (10), T2.5 (8), S2 (6), S3 (8)
Q	8000 kPa 80 bar 1160 psi	-8000 kPa -80 bar -1160 psi	0.07 kPa abs (§) 0.7 mbar abs (§) 0.5 mmHg (§)	0.07 kPa abs (§) 0.7 mbar abs (§) 0.5 mmHg (§)	134 kPa 1.34 bar 19.4 psi	267 kPa 2.67 bar 38.7 psi	P1.5, P2, P3, F2, F3, E2, E3, T2.5, K1.5, S2, S3, Jx (all)	P1.5 (5), P2 (8), P3 (10), F2 (16), F3 (16), E2 (6), E3 (10), T2.5 (8), S2 (6), S3 (8)
S	16000 kPa 160 bar 2320 psi	-16000 kPa -160 bar -2320 psi	0.07 kPa abs (§) 0.7 mbar abs (§) 0.5 mmHg (§)	0.07 kPa abs (§) 0.7 mbar abs (§) 0.5 mmHg (§)	267 kPa 2.67 bar 38.7 psi	534 kPa 5.34 bar 77.4 psi	P1.5, P2, P3, F2, F3, T2.5, Jx (all)	P1.5 (5), P2 (8), P3 (10), F2 (16), F3 (16), T2.5 (8)

(Δ) 0.07 kPa abs, 0.7 mbar abs, 0.5 mmHg for model 266NDH

(§) Lower Range Limit is 0.135 kPa abs, 1.35 mbar abs, 1 mmHg for inert Galden or 0.4 kPa abs, 4 mbar abs, 3 mmHg for inert Halocarbon.

### Span limits

Maximum span = URL (can be further adjusted up to ± URL (TD = 0.5) for differential models, within the range limits)  
IT IS RECOMMENDED TO SELECT THE TRANSMITTER SENSOR CODE PROVIDING THE TURNDOWN VALUE AS LOWEST AS POSSIBLE TO OPTIMIZE PERFORMANCE CHARACTERISTICS.

### Zero suppression and elevation

Zero and span can be adjusted to any value within the range limits detailed in the table as long as:

– calibrated span ≥ minimum span

### Damping

Selectable time constant : between 0 and 60 s  
This is in addition to sensor response time.

### Turn on time

Operation within specification in less than 10 s with minimum damping.

### Insulation resistance

> 100 MΩ at 500 V DC (terminals to earth)

# Model 266DDH Differential

# Model 266HDH Gauge

# Model 266NDH Absolute

## Operative limits

**REFER ALSO TO S26X DATA SHEET FOR POSSIBLE FURTHER LIMITATION DUE TO SEAL VARIANTS AND FOR DATA RELEVANT TO THE POSSIBLE REMOTE SEAL (IF SELECTED ON NEGATIVE SIDE)**

**Pressure limits:**

### Overpressure limits

Without damage to the transmitter

Model 266DDH	Fill fluid	Overpressure limits
Sensor F to S	Silicone oil	0.07 kPa abs, 0.7 mbar abs, 0.5 mmHg and 21 MPa, 210 bar, 3045 psi <sup>(1)</sup>
Sensor E	Silicone oil	0.07 kPa abs, 0.7 mbar abs, 0.5 mmHg and 16 MPa, 160 bar, 2320 psi
Sensor F to S	Inert (Galden)	0.135 kPa abs, 1.35 mbar abs, 1 mmHg and 21 MPa, 210 bar, 3045 psi <sup>(1)</sup>
Sensor E	Inert (Galden)	0.135 kPa abs, 1.35 mbar abs, 1 mmHg and 16 MPa, 160 bar, 2320 psi
Sensor F to S	Inert (Halocarbon)	0.4 kPa abs, 4 mbar abs, 3 mmHg and 21 MPa, 210 bar, 3045 psi <sup>(1)</sup>
Sensor E	Inert (Halocarbon)	0.4 kPa abs, 4 mbar abs, 3 mmHg and 16 MPa, 160 bar, 2320 psi

(1) 16 MPa, 160 bar, 2320 psi for AISI 316 ss NACE bolting

Models 266HDH and 266NDH	Fill fluid	Overpressure limits
Sensor P, Q, S	Silicone oil	0.07 kPa abs, 0.7 mbar abs, 0.5 mmHg and 21 MPa, 210 bar, 3045 psi
Sensor G, H, M	Silicone oil	0.07 kPa abs, 0.7 mbar abs, 0.5 mmHg and 14 MPa, 140 bar, 2030 psi
Sensor P, Q, S	Inert (Galden)	0.135 kPa abs, 1.35 mbar abs, 1 mmHg and 21 MPa, 210 bar, 3045 psi
Sensor G, H, M	Inert (Galden)	0.135 kPa abs, 1.35 mbar abs, 1 mmHg and 14 MPa, 140 bar, 2030 psi
Sensor P, Q, S	Inert (Halocarbon)	0.4 kPa abs, 4 mbar abs, 3 mmHg and 21 MPa, 210 bar, 3045 psi
Sensor G, H, M	Inert (Halocarbon)	0.4 kPa abs, 4 mbar abs, 3 mmHg and 14 MPa, 140 bar, 2030 psi

## Static pressure limits

Transmitters for differential pressure model 266DDH operates within specifications between the following limits:

Sensors	Static pressure limits
Sensor F to S with 2 seals (direct mount and remote)	0.07 kPa abs, 0.7 mbar abs, 0.5 mmHg and 21 MPa, 210 bar, 3045 psi <sup>(1)</sup>
Sensor F to S with 1 seal (direct mount only)	1.3 kPa abs, 13 mbar abs, 0.2 psia and 21 MPa, 210 bar, 3045 psi <sup>(1)</sup>
Sensor E with 2 seals (direct mount and remote)	0.07 kPa abs, 0.7 mbar abs, 0.5 mmHg and 16 MPa, 160 bar, 2320 psi
Sensor E with 1 seal (direct mount only)	1.3 kPa abs, 13 mbar abs, 0.2 psia and 16 MPa, 160 bar, 2320 psi

(1) 16 MPa, 160 bar, 2320 psi for AISI 316 ss NACE bolting

Overpressure and static upper limit can be derated by the flange rating of seal, as follows

Seal model S26RE to EN 1092-1	Carbon steel flange @ 120 °C	AISI 316 ss flange @ 20 °C
PN 16	16 bar	16 bar
PN 40	40 bar	40 bar
PN 63	63 bar	63 bar
PN 100	100 bar	100 bar

Seal model S26RA and S26RR to ASME B16.5	Carbon Steel @ 100 °F (38 °C)	AISI 316 ss flange @ 100 °F (38 °C)
Class 150	285 psi	275 psi
Class 300	740 psi	720 psi
Class 600	1480 psi	1440 psi
Class 900	2220 psi	2160 psi
Class 1500	3705 psi	3600 psi

Seal model S26RJ to JIS B 2220	Carbon steel flange @ 120 °C	AISI 316 ss flange @ 120 °C
10K	14 bar	14 bar
20K	36 bar	36 bar
40K	68 bar	68 bar

Seal model S26FE to EN 1092-1	AISI 316 L ss flange @ 20 °C
PN 16	16 bar
PN 40	40 bar
PN 63	63 bar
PN 100	100 bar

Seal model S26FA to ASME B16.5	AISI 316 L ss flange @ 100 °F (38 °C)
Class 150	230 psi
Class 300	600 psi
Class 600	1200 psi

<b>Seal model S26ME to EN 1092-1</b>	<b>AISI 316 ss or Hastelloy C flange</b>
PN 16 / 40	34 bar @ 25 °C (77 °F)

<b>Seal model S26MA to ASME B16.5</b>	<b>AISI 316 L ss flange @ 25 °C (77 °F)</b>	<b>Hastelloy C flange @ 25 °C (77 °F)</b>
Class 150	230 psi	290 psi
Class 300	600 psi	750 psi

The pressure limit decreases with increasing temperature above to the specified values as defined for the material, respectively for ASME B16.5, EN 1092-1 or JIS standards.

Seal model S26TT bolting	Temperature range	Pressure limit
AISI 316 ss or Carbon steel	0 ... 100 °C (32 ... 212 °F)	21 MPa, 210 bar, 3045 psi
	-60 ... 0 °C (-76 ... 32 °F)	16 MPa, 160 bar, 2320 psi
	100 ... 360 °C (212 ... 680 °F)	16 MPa, 160 bar, 2320 psi
Alloy steel	0 ... 37.8 °C (32 ... 100 °F)	21 MPa, 210 bar, 3045 psi
	-48.3 ... 0 °C (-55 ... 32 °F)	16 MPa, 160 bar, 2320 psi
	37.8 ... 360 °C (100 ... 680 °F)	13 MPa, 130 bar, 1885 psi

<b>Seal model S26JN</b>
up to 16 MPa, 160 bar, 2320 psi
but not greater than rating of mounting flange (NOT SUPPLIED)

<b>Seal model S26WA to ASME B16.5</b>
up to 41.37 MPa, 413.7 bar, 6000 psi
but not greater than rating of mounting flange (NOT SUPPLIED)

<b>Seal model S26WE to EN 1092-1</b>	
Form B1	40 MPa, 400 bar, 5800 psi
Form D	16 MPa, 160 bar, 2320 psi
Form E	10 MPa, 100 bar, 1450 psi
but not greater than rating of mounting flange (NOT SUPPLIED)	

<b>Seal model S26KN</b>	
1 in seal - sealing with gaskets	3 MPa, 30 bar, 435 psi
1 1/2 in seals - sealing with gasket	5 MPa, 50 bar, 725 psi
1 in seal with ball valve connection	4 MPa, 40 bar, 580 psi
1 in NPT, 1 1/2 in NPT	34.5 MPa, 345 bar, 5000 psi
G 1 in A, G 1 1/2 in A	60 MPa, 600 bar, 8700 psi

Seal model S26VN bolting	Temperature range	Pressure limit
Alloy steel	0 ... 37.8 °C (32 ... 100 °F)	16 MPa, 160 bar, 2320 psi
	-48.3 ... 0 °C (-55 ... 32 °F)	10 MPa, 100 bar, 1450 psi
	37.8 ... 360 °C (100 ... 680 °F)	10 MPa, 100 bar, 1450 psi

Seal model S26SS	Pressure limit
Triclamp 2 in.	3.8 MPa, 38 bar, 550 psi
Triclamp 3 in.	2.4 MPa, 24 bar, 350 psi
Triclamp 4 in.	1.7 MPa, 17 bar, 250 psi
Union nut F50	2.5 MPa, 25 bar, 360 psi
Union nut F80	2.5 MPa, 25 bar, 360 psi
Cherry Burrel 2 in.	1.9 MPa, 19 bar, 275 psi
Cherry Burrel 3 in.	1.9 MPa, 19 bar, 275 psi
Cherry Burrel 4 in.	1.9 MPa, 19 bar, 275 psi
Sanitary flush 4 in.	1.9 MPa, 19 bar, 275 psi
Sanitary extended 4 in.	1.9 MPa, 19 bar, 275 psi
Beverage bolted type 1 1/2 in.	4 MPa, 40 bar, 580 psi
V-band clamp option	1 MPa, 10 bar, 145 psi
4in schedule 5 V-band clamp option	0.7 MPa, 7 bar, 100 psi

### Proof pressure

The transmitter can be exposed without leaking to line pressure of up to

Model	Sensor	Proof pressure
266DDH	Sensor F to S	40.25 MPa, 402.5 bar, 5836 psi
	Sensor E	31.5 MPa, 315 bar, 4567 psi
266HDH	Sensor G, H, M	28 MPa, 280 bar, 4060 psi
266NDH	Sensor P, Q, S	40.25 MPa, 402.5 bar, 5836 psi

or two times the flange rating of seal, whichever is less. Meet ANSI/ISA-S 82.03 hydrostatic test requirements.

# Model 266DDH Differential

## Model 266HDH Gauge

## Model 266NDH Absolute

### Temperature limits °C ( °F ) :

#### Ambient

is the operating temperature

Models 266DDH	Ambient temperature limits
Silicone oil for sensor F to S	-40 and 85 °C (-40 and 185 °F)
Silicone oil for sensor E	-25 and 85 °C (-13 and 185 °F)
Inert (Galden) for sensor F to S	-20 and 85 °C (-4 and 185 °F)
Inert (Galden) for sensor E	-10 and 85 °C (14 and 185 °F)
Inert (Halocarbon) for sensor F to S	-20 and 85 °C (-4 and 185 °F)
Inert (Halocarbon) for sensor E	-10 and 85 °C (14 and 185 °F)

Model 266HDH - 266NDH	Ambient temperature limits
Silicone oil for sensor G to S	-40 and 85 °C (-40 and 185 °F)
Inert (Galden) for sensor G to S	-20 and 85 °C (-4 and 185 °F)
Inert (Halocarbon) for sensor G to S	-20 and 85 °C (-4 and 185 °F)

Models 266DDH - 266HDH - 266NDH	Ambient temperature limits
LCD integral display	-40 and 85 °C (-40 and 185 °F)

LCD display may not be clearly readable below -20 °C (-4 °F) or above +70 °C (+158 °F)

### IMPORTANT

For Hazardous Atmosphere applications see the temperature range specified on the certificate/approval relevant to the aimed type of protection

### Process

Model 266DDH (side without seal)	Process temperature limits
Silicone oil for sensor F to S	-40 and 121 °C (-40 and 250 °F) <sup>(1)</sup>
Silicone oil for sensor E	-25 and 121 °C (-13 and 250 °F) <sup>(1)</sup>
Inert (Galden) for sensor F to S	-20 and 100 °C (-4 and 212 °F) <sup>(2)</sup>
Inert (Galden) for sensor E	-10 and 100 °C (14 and 212 °F) <sup>(2)</sup>
Inert (Halocarbon) for sensor F to S	-20 and 100 °C (-4 and 212 °F) <sup>(2)</sup>
Inert (Halocarbon) for sensor E	-10 and 100 °C (14 and 212 °F) <sup>(2)</sup>
Viton gasket	-20 and 121 °C (-4 and 250 °F)

(1) 100 °C (212 °F) for application below atmospheric pressure

(2) 65 °C (150 °F) for application below atmospheric pressure

Seals model (mnemonic)	Process temperature limits
S26JN In-line type (J1, J1.5, J2, J3)	-40 and 180 °C (-40 and 356 °F)
S26KN Pulp & Paper (M1, M1.5 all)	-40 and 150 °C (-40 and 302 °F)
S26KN Pulp & Paper (Y1)	-20 and 130 °C (-4 and 266 °F)
S26SS Beverage (K1.5)	-40 and 150 °C (-40 and 302 °F)
S26XX (ALL OTHER MNEMONICS)	-100 and 250 °C (-148 and 480 °F)

Seals model S26VN	Process temperature limits
Viton gasket	-20 and 200 °C (-4 and 392 °F)
PTFE gasket	-100 and 260 °C (-148 and 500 °F)
Graphite gasket	-100 and 360 °C (-148 and 680 °F)

The following table show characteristics of fill fluids when used in transmitters with direct mount seal on high pressure side.

Fill fluid (application)	Process temperature and pressure limits			
	Tmax @ Pabs > of	Pmin mbar abs (mmHg)	Tmax @ Pmin	Tmin
Silicone oil DC 200 10 cSt	250 (480) @ 385 mbar	0.7 (0.5)	130 (266)	-40 (-40)
Silicone oil Baysilone PD5 5 cSt	250 (480) @ 900 mbar	0.7 (0.5)	45 (123)	-50 (-58)
Inert oil Galden G5 (oxygen service)	160 (320) @ 1 bar	2.1 (1.52)	60 (140)	-20 (-4)
Inert oil Halocarbon 4.2 (oxygen service)	180 (356) @ 425 mbar	4 (3)	70 (158)	-20 (-4)
Silicone polymer Syltherm XLT (cryogenic service)	100 (212) @ 118 mbar	2.1 (1.52)	20 (68)	-100 (-148)
Silicone oil DC 704 (high temperature)	250 (480) @ 3.5 mbar	0.7 (0.5)	220 (428)	-10 (14)
Vegetable oil Neobee M-20 (food - sanitary) FDA approved	200 (390) @ 1 bar	10 (7.2)	20 (68)	-18 (0)
Mineral oil Esso Marcol 122 (food - sanitary) FDA approved	250 (480) @ 630 mbar	0.7 (0.5)	110 (230)	-6 (21)
Glycerin Water 70% (food - sanitary) FDA approved	93 (200) @ 1 bar	1000 (760)	93 (200)	-7 (20)

Flushing ring gasket material	Process limits		
	Pressure (max.)	Temperature	P x T
Garlock	6.9 MPa, 69 bar, 1000 psi	-73 and 204 °C (-100 and 400 °F)	250000 ( °F x psi)
Graphite	2.5 MPa, 25 bar, 362 psi	-100 and 380 °C (-148 and 716 °F)	
PTFE	6 MPa, 60 bar, 870 psi	-100 and 250 °C (-148 and 482 °F)	

### Storage

Models 266DDH - 266HDH - 266NDH	Storage temperature limits
Storage limits	-50 and 85 °C (-58 and 185 °F)
LCD integral display	-40 and 85 °C (-40 and 185 °F)

## Environmental limits

### Electromagnetic compatibility (EMC)

Comply with EN 61326 and NAMUR NE-21

Surge immunity level (with surge protector): 4 kV  
(according to IEC 1000-4-5 EN 61000-4-5)

### Pressure equipment directive (PED)

Comply with 97/23/EEC following sound engineering practice (SEP).

### Humidity

Relative humidity: up to 100 %

Condensing, icing: admissible

### Vibration resistance

Accelerations up to 2 g at frequency up to 1000 Hz  
(according to IEC 60068-2-6)

### Shock resistance

Acceleration: 50 g

Duration: 11 ms

(according to IEC 60068-2-27)

### Wet and dust-laden atmospheres

The transmitter is dust and sand tight and protected against immersion effects as defined by EN 60529 (1989) to IP 67 (IP 68 on request) or by NEMA to 4X or by JIS to C0920. IP65 with Harting Han connector.

### Hazardous atmospheres

With or without integral display

---

INTRINSIC SAFETY:

ATEX Europe (code E1) and IEC Ex (code E8) approval

II 1 G Ex ia IIC T6 and

II 1/2 G Ex ia IIC T6 (-40 °C ≤ Ta ≤ +40 °C);

II 1 D Ex iaD 20 T 95 °C and

II 1/2 D Ex iaD 21 T95 °C

---

EXPLOSION PROOF:

ATEX Europe (code E2) and IEC Ex (code E9) approval

II 1/2 G Ex d IIC T6 and

II 1/2 D Ex tD A21 IP67 T85 °C

---

TYPE "N":

ATEX Europe (code E3 ) and IEC Ex (code ER)

type examination

II 3 G Ex nL IIC T6 and

II 3 D Ex tD A22 IP67 T85 °C

---

FM Approvals US (code E6) and

FM Approvals Canada (code E4):

– Explosionproof (US): Class I, Div. 1, Groups A, B, C, D

– Explosionproof (Canada): Class I, Div. 1, Groups B, C, D

– Dust ignitionproof : Class II, Div. 1, Groups E, F, G

– Suitable for: Class II, Div. 2, Groups F, G; Class III, Div.1, 2

– Nonincendive: Class I, Div. 2, Groups A, B, C, D

– Intrinsically safe: Class I, II, III, Div. 1, Groups A, B, C, D, E, F, G

Class I, Zone 0 AEx ia IIC T6/T4, Zone 0 (FM US)

Class I, Zone 0 Ex ia IIC T6/T4, Zone 0 (FM Canada)

---

COMBINED ATEX (code EW = E1 + E2 + E3)

---

COMBINED ATEX and FM Approvals (code EN = EW + E4 + E6)

---

COMBINED FM Approvals US and Canada

– Intrinsically safe (code EA)

– Explosionproof (code EB)

– Nonincendive (code EC)

---

– GOST (Russia), GOST (Kazakhstan), Inmetro (Brazil)

based on ATEX

---

# Model 266DDH Differential

# Model 266HDH Gauge

# Model 266NDH Absolute

## Electrical Characteristics and Options

### HART digital communication and 4 to 20 mA output

#### Power Supply

The transmitter operates from 10.5 to 42 V DC with no load and is protected against reverse polarity connection (additional load allows operations over 42 V DC).

For EEx ia and other intrinsically safe approval power supply must not exceed 30 V DC.

Minimum operating voltage increase to 12.3 V DC with optional surge protector

#### Ripple

20 mV max on a 250  $\Omega$  load as per HART specifications.

#### Load limitations

4 to 20 mA and HART total loop resistance :

$$R \text{ (k}\Omega\text{)} = \frac{\text{Supply voltage} - \text{min. operating voltage (V DC)}}{22 \text{ mA}}$$

A minimum of 250  $\Omega$  is required for HART communication.

#### Optional indicators

##### Integral display (code L1)

Wide screen LCD, 128 x 64 pixel,

52.5 x 27.2 mm (2.06 x 1.07 in.) dot matrix. Multilanguage.

Four keys for configuration and management of device.

Easy setup for quick commissioning.

User selectable application-specific visualizations.

Totalized and instantaneous flow indication.

Display may also indicate static pressure, sensor temperature and diagnostic messages and provides configuration facilities.

##### Through-the-glass (TTG) controlled display (code L5)

As above integral display but equipped with the innovative TTG keypad allowing the activation of the configuration and management menus of the device without the need of removing the transmitter housing cover.

TTG keypad is protected against accidental activations.

### Optional surge protection

Up to 4kV

- voltage 1.2  $\mu$ s rise time / 50  $\mu$ s delay time to half value

- current 8  $\mu$ s rise time / 20  $\mu$ s delay time to half value

### Output signal

Two-wire 4 to 20 mA, user-selectable for linear or square root output, power of  $^{3/2}$  or  $^{5/2}$ , square root for bidirectional flow, 22 points linearization table (i.e. for horizontal or spherical tank level measurement).

HART<sup>®</sup> communication provides digital process variable superimposed on 4 to 20 mA signal, with protocol based on Bell 202 FSK standard.

### Output current limits (to NAMUR standard)

Overload condition

- Lower limit: 3.8 mA (configurable from 3.8 to 4 mA)

- Upper limit: 20.5 mA (configurable from 20 to 21 mA)

### Alarm current

- Lower limit: 3.6 mA (configurable from 3.6 to 4 mA)

- Upper limit: 21 mA (configurable from 20 to 22 mA)

Factory setting: high alarm current

### Process diagnostics (PILD)

Plugged impulse line detection (PILD) generates a warning via HART communication. The device can also be configured to drive the analog output signal to the "Alarm current".



## **FOUNDATION Fieldbus output**

### **Device type**

LINK MASTER DEVICE

Link Active Scheduler (LAS) capability implemented.

Manufacturer code: 000320 (hex)

Device type code: 0007 (hex)

### **Power supply**

The transmitter operates from 9 to 32 V DC, polarity independent, with or without surge protector.

For EEx ia approval power supply must not exceed 24 V DC (entity certification) or 17.5 V DC (FISCO certification), according to FF-816.

### **Current consumption**

operating (quiescent): 15 mA

fault current limiting: 20 mA max.

### **Output signal**

Physical layer in compliance to IEC 1158-2/EN 61158-2 with transmission to Manchester II modulation, at 31.25 kbit/s.

### **Function blocks/execution period**

3 enhanced Analog Input blocks/25 ms max (each)

1 enhanced PID block/40 ms max.

1 standard ARithmetic block/25 ms

1 standard Input Selector block/25 ms

1 standard Control Selector block/25 ms

1 standard Signal Characterization block/25 ms

1 standard Integrator/Totalizer block/25 ms

### **Additional blocks**

1 enhanced Resource block,

1 custom Pressure with calibration transducer block

1 custom Advanced Diagnostics transducer block including Plugged Input Line Detection

1 custom Local Display transducer block

### **Number of link objects**

35

### **Number of VCRs**

35

## **Output interface**

FOUNDATION fieldbus digital communication protocol to standard H1, compliant to specification V. 1.7.

### **Integral display**

Wide screen LCD, 128 x 64 pixel,

52.5 x 27.2 mm (2.06 x 1.07 in.) dot matrix. Multilanguage.

Four keys for configuration and management of device.

Easy setup for quick commissioning.

User selectable application-specific visualizations.

Totalized and instantaneous flow indication.

Display may also indicate static pressure, sensor temperature and diagnostic messages and provides configuration facilities.

### **Transmitter failure mode**

The output signal is "frozen" to the last valid value on gross transmitter failure condition, detected by self-diagnostics which also indicate a BAD conditions. If electronic failure or short circuit occur the transmitter consumption is electronically limited at a defined value (20 mA approx), for safety of the network.

# Model 266DDH Differential

## Model 266HDH Gauge

## Model 266NDH Absolute

### PROFIBUS PA output

#### Device type

Pressure transmitter compliant to Profiles 3.0.1  
Identification number: 3450 (hex)

#### Power supply

The transmitter operates from 9 to 32 V DC , polarity independent, with or without surge protector.  
For EEx ia approval power supply must not exceed 17.5 V DC.  
Intrinsic safety installation according to FISCO model.

#### Current consumption

operating (quiescent): 15 mA  
fault current limiting: 20 mA max.

#### Output signal

Physical layer in compliance to IEC 1158–2/EN 61158–2 with transmission to Manchester II modulation, at 31.25 kbit/s.

#### Output interface

PROFIBUS PA communication according to Profibus DP50170 Part 2/DIN 19245 part 1–3.

#### Output update time

25 ms

#### Function blocks

3 analog input, 3 transducer, 1 physical.

#### Integral display

Wide screen LCD, 128 x 64 pixel,  
52.5 x 27.2 mm (2.06 x 1.07 in.) dot matrix. Multilanguage.  
Four keys for configuration and management of device.  
Easy setup for quick commissioning.  
User selectable application-specific visualizations.  
Instantaneous flow indication.  
Display may also indicate static pressure, sensor temperature and diagnostic messages and provides configuration facilities.

#### Transmitter failure mode

On gross transmitter failure condition, detected by self-diagnostics, the output signal can be driven to defined conditions, selectable by the user as safe, last valid or calculated value.

If electronic failure or short circuit occur the transmitter consumption is electronically limited at a defined value (20 mA approx), for safety of the network.

## Performance specifications

Stated at reference condition to IEC 60770 ambient temperature of 20 °C (68 °F), relative humidity of 65 %, atmospheric pressure of 1013 hPa (1013 mbar), mounting position with vertical diaphragm and zero based range for transmitter with isolating diaphragms in AISI 316 L ss or Hastelloy and silicone oil fill and HART digital trim values equal to 4 mA and to 20 mA span end points, in linear mode. Unless otherwise specified, errors are quoted as % of span. Some performance referring to the Upper Range Limit are affected by the actual turndown (TD) as ratio between Upper Range Limit (URL) and calibrated span.

IT IS RECOMMENDED TO SELECT THE TRANSMITTER SENSOR CODE PROVIDING THE TURNDOWN VALUE AS LOWEST AS POSSIBLE TO OPTIMIZE PERFORMANCE CHARACTERISTICS.

#### Accuracy rating

% of calibrated span, including combined effects of terminal based linearity, hysteresis and repeatability.

For fieldbus versions SPAN refer to analog input function block outscale range

Model	Sensor	for TD up to	
266DDH	F and G	from 1:1 to 10:1	± 0.06 %
with seals	F and G	from 10:1 to 60:1	± (0.006 x TD) %
mnemonic	H to S	from 1:1 to 10:1	± 0.075 %
P3, F3, E3, S3,	H to S	from 10:1 to 60:1	± (0.0075 x TD) %
K1.5, F2	E	from 1:1 to 5:1	± 0.10 %
	E	from 5:1 to 20:1	± (0.02 x TD) %
266DDH with	F to S	from 1:1 to 10:1	± 0.10 %
seals mnemonic	F to S	from 10:1 to 60:1	± (0.01 x TD) %
different from	E	from 1:1 to 5:1	± 0.15 %
above	E	from 5:1 to 20:1	± (0.03 x TD) %

### Accuracy rating

% of calibrated span, including combined effects of terminal based linearity, hysteresis and repeatability.

For fieldbus versions SPAN refer to analog input function block outscale range

Model	Sensor	for TD up to	
266HDH with seals mnemonic	M and P	from 1:1 to 10:1	± 0.06 %
	M and P	from 10:1 to 60:1	± (0.006 x TD) %
P3, F3, E3, S3, K1.5, F2	G, H, Q, S	from 1:1 to 10:1	± 0.075 %
	G, H, Q, S	from 10:1 to 60:1	± (0.0075 x TD) %
266HDH with seals mnemonic Y1	H and M	from 1:1 to 5:1	± 0.15 %
	H and M	from 5:1 to 30:1	± (0.03 x TD) %
	P, Q	from 1:1 to 5:1	± 0.075 %
	P, Q	from 5:1 to 30:1	± (0.015 x TD) %
266HDH with seals mnemonic M1	H and M	from 1:1 to 5:1	± 0.15 %
	H and M	from 5:1 to 30:1	± (0.03 x TD) %
	P, Q, S	from 1:1 to 5:1	± 0.075 %
	P, Q, S	from 5:1 to 30:1	± (0.015 x TD) %
266HDH with seals mnemonic M1.5, M1.5B	G, H, M,	from 1:1 to 5:1	± 0.075 %
	P, Q	from 5:1 to 30:1	± (0.015 x TD) %
266HDH with seals mnemonic M1.5A	G, H, M,	from 1:1 to 5:1	± 0.075 %
	P, Q, S	from 5:1 to 30:1	± (0.015 x TD) %
266HDH with seals different from above	G, H, M,	from 1:1 to 10:1	± 0.10 %
	P, Q, S	from 10:0 to 60:1	± (0.01 x TD) %
266NDH with seals mnemonic P3, F3, E3, S3, K1.5, F2	G, H, M,	from 1:1 to 10:1	± 0.10 %
	P, Q, S	from 10:1 to 60:1	± (0.01 x TD) %
266NDH with seals mnemonic M1	H and M	from 1:1 to 5:1	± 0.20 %
	H and M	from 5:1 to 30:1	± (0.04 x TD) %
	P, Q, S	from 1:1 to 5:1	± 0.10 %
	P, Q, S	from 5:1 to 30:1	± (0.02 x TD) %
266NDH with seals mnemonic M1.5, M1.5B	G, H, M,	from 1:1 to 5:1	± 0.10 %
	P, Q	from 5:1 to 30:1	± (0.02 x TD) %
266NDH with seals mnemonic M1.5A	G, H, M,	from 1:1 to 5:1	± 0.10 %
	P, Q, S	from 5:1 to 30:1	± (0.02 x TD) %
266NDH with seals different from above	G, H, M,	from 1:1 to 10:1	± 0.15 %
	P, Q, S	from 10:1 to 60:1	± (0.015 x TD) %

### Ambient temperature

Transmitter effect per 20K change between the limits of -40 °C to +85 °C (per 36 °F change between the limits of -40 to +185 °F):

Model	Sensor	for TD up to	
266DDH	E to S	10 : 1	± (0.04 % URL + 0.065 % span)
266HDH	G to S	10 : 1	± (0.04 % URL + 0.065 % span)
266NDH	G to S	10 : 1	± (0.08 % URL + 0.13 % span)

REFER TO S26 SEALS DATA SHEET FOR TEMPERATURE ADDITIONAL EFFECTS OF DIRECT MOUNT SEAL AND REMOTE SEAL (if selected on negative side).

For paper and in-line seal, available only as direct mount, refer respectively to the following tables of temperature effects per 20 K (36 °F) changes, detailed separately for

- the seal (one element), as process temperature error  
- the system (transmitter sensor when combined with a seal of specific size/type) referred to silicone oil (DC 200) filling and AISI 316 L ss diaphragm materials. .

S26K paper seal size - Mnemonic	Sensor URL	Seal error (process)	Direct mount error (ambient)
1 in. - Y1	≥ 160 kPa, 642 inH2O	1.2 kPa, 4.8 inH2O	0.64 kPa, 2.56 inH2O
1 in. - M1	≥ 160 kPa, 642 inH2O	0.6 kPa, 2.4 inH2O	0.64 kPa, 2.56 inH2O
1 1/2 in. - M1.5	≥ 65 kPa, 260 inH2O	0.2 kPa, 0.8 inH2O	0.48 kPa, 1.92 inH2O
1 1/2 in. - M1.5A	≥ 65 kPa, 260 inH2O	0.2 kPa, 0.8 inH2O	0.48 kPa, 1.92 inH2O
1 1/2 in. - M1.5B	≥ 65 kPa, 260 inH2O	0.2 kPa, 0.8 inH2O	0.48 kPa, 1.92 inH2O

S26J in-line seal size - Mnemonic	Sensor URL	Seal error (process)	Direct mount error (ambient)
1 in. - J1	≥ 600 kPa, 87 psi	2.2 kPa, 8.8 inH2O	0.94 kPa, 3.76 inH2O
1 1/2 in. - J1.5	≥ 600 kPa, 87 psi	1.4 kPa, 5.6 inH2O	0.36 kPa, 1.44 inH2O
2 in. - J2	≥ 600 kPa, 87 psi	4.6 kPa, 18.4 inH2O	0.94 kPa, 3.76 inH2O
4 in. - J3	≥ 600 kPa, 87 psi	3.0 kPa, 12 inH2O	0.42 kPa, 1.68 inH2O

### Static pressure

(zero errors can be calibrated out at line pressure)

per 2 MPa, 20 bar or 290 psi

Model 266DDH with direct mount seal only

– zero error: ±0.15% of URL

– span error: ±0.15% of reading

Model 266DDH with direct mount plus remote seal

– zero error: ±0.20% of URL

– span error: ±0.20% of reading

### Supply voltage

Within voltage/load specified limits the total effect is less than 0.005 % of URL per volt.

### Load

Within load/voltage specified limits the total effect is negligible.

### Electromagnetic field

Meets all the requirements of EN 61326 and NAMUR NE-21.

### Common mode interference

No effect from 100Vrms @ 50Hz, or 50 V DC

# Model 266DDH Differential

## Model 266HDH Gauge

## Model 266NDH Absolute

### Physical Specification

(Refer to ordering information sheets for variant availability related to specific model or versions code)

#### **Model 266DDH only**

##### **Low pressure side process isolating diaphragms (\*)**

AISI 316 L ss; Hastelloy C-276™; Monel 400™; Tantalum.  
A remote seal can be selected with required diaphragm material (refer to high pressure side).

##### **Low pressure side process flanges, adapters, plugs and drain/vent valves (\*)**

AISI 316 L ss; Hastelloy C-276™; Monel 400™.

##### **Bolts and nuts**

AISI 316 ss bolts Class A4–80 and nuts Class A4-70 per UNI 7323 (ISO 3506);

AISI 316 ss bolts and nuts Class A4–50 per UNI 7323 (ISO 3506), in compliance with NACE MR0175 Class II.

##### **Gaskets (\*)**

Viton™; PTFE.

#### **Model 266DDH / HDH / NDH**

##### **High pressure side process diaphragm (direct mount seal) (\*)**

AISI 316 L ss; Hastelloy C-276™; Hastelloy C-2000™; Inconel 625; Tantalum; AISI 316 L ss or Hastelloy C-276™ with anti-stick coating; AISI 316 L ss with anti-corrosion coating; AISI 316 L ss gold plated; Superduplex ss (UNS S32750 to ASTM SA479);

Diaflex (AISI with anti-abrasion treatment).

##### **Extension material**

AISI 316 L ss (also for Diaflex and gold plated diaphragms); Hastelloy C-276™; AISI 316 L ss or Hastelloy C-276™ with coating same as diaphragm

##### **High pressure side fill fluid (direct mount seal)**

Silicone oil-DC200™; Silicone oil-DC704™; Inert-Galden™; Inert-Halocarbon™ 4.2; Silicone Polymer-Syltherm XLT™; Low viscosity silicone oil-Baysilone M5; Glycerin Water; Vegetable oil-Neobee M-20™; Mineral oil-Essomarcil 122™.

##### **Sensor fill fluid**

Silicone oil; Inert fill (Halocarbon™ 4.2 or Galden™).

##### **Sensor housing**

AISI 316 L ss.

##### **Electronic housing and covers**

Aluminium alloy (copper content  $\leq 0.3$  %) with baked epoxy finish (colour RAL9002);

AISI 316 L ss.

##### **Covers O-ring**

Buna N.

##### **Local adjustments (zero, span and write protect)**

Glass filled polyphenylene oxide (removable).

##### **Plates**

AISI 316ss for transmitter nameplate, certification plate, optional tag/calibration plate attached to the electronics housing and optional wired-on customer data plate. All printing by laser.

##### **Calibration**

Standard: at maximum span, zero based range, ambient temperature and pressure;

Optional: at specified range and ambient conditions.

##### **Optional extras**

##### **Display**

4-position (at 90°) user orientable.

##### **Optional plates**

Code I2: for tag (up to 31 characters) and calibration details (up to 31 characters: lower and upper values plus unit) fixed onto transmitter housing.

Code I1: for customer data (32 character x 4 lines) wired-on transmitter housing

##### **Surge protection**

##### **Test Certificates (test, design, calibration, material traceability)**

##### **Tag and manual language**

##### **Communication connectors**

### Process connections

on conventional flanges : 1/4 – 18 NPT on process axis;  
on adapters : 1/2 – 14 NPT on process axis;  
fixing threads: 7/16 – 20 UNF at 41.3mm centre distance;  
on seal side (refer to drawings for details):

#### Flush diaphragm flanged seal (\*\*):

2 in. or 3 in. ASME 150 to 1500 RF; 4 in. ASME 150-300 RF;  
1-1/2 in., 2 in. or 3 in. ASME 150 to 1500 RJ;  
DN 50 or DN 80 PN 16–40, PN 63–100; DN 100 PN 16–40;  
A50 or A80 Class 10K, 20K, 40K; A100 Class 10K, 20K.

#### Extended diaphragm flanged seal (\*\*):

2 in., 3 in. or 4 in. ASME 150 - 300 RF;  
DN 50, DN 80 or DN 100 PN 16 – 40.

#### Off-line flanged connection seal (\*\*\*)

1/2 in., 1 in. or 1-1/2 in. hole connection, ASME CL150-300;  
DN 25 or DN 40, EN PN 16-40.

#### Off-line threaded connection seal

1/4 in., 1/2 in., 3/4 in., 1 in. or 1-1/2 in. NPT thread.

#### Food/Sanitary seal

Triclamp: 2 in., 3 in. or 4 in.;

Union nut: F50 or F80 to DIN 11851;

Cherry Burrell: 2 in., 3 in. or 4 in.;

Sanitary: 4in flush diaphragm or 4in extended (2in, 4in or 6in) diaphragm

Beverage bolted: 1/2 in. flush diaphragm with integral 6 holes flanged connection

#### Pulp & paper seal

1 in. sealing with gasket for weld spud with fixing by screw

1-1/2 in. sealing with gasket for weld spud with fixing by screws

1-1/2 in. sealing with gasket for weld spud with M44 x 1.25 threaded connection

1 in. or 1-1/2 in. with NPT male threaded connection

G 1 in. A or G 1-1/2 in. A male threaded connection

1 in. for ball valve connection

#### Saddle & Socket seal

2 in., 2-1/2 in., 3 in., 4 in., 5 in. or 6 in. saddle connection

1/2 in., 3/4 in., 1 in., 1-1/2 in. or 2 in. socket connection

#### In-line seal

DN25 / 1 in., DN40 / 1-1/2 in., DN 50 / 2 in., DN80 / 3 in.

#### Wafer seal (remote only)

1-1/2 in., 2 in. or 3 in. to ASME; DN 40, DN 50 or DN 80 to EN.

#### Gasket seat finish (as applicable to specific seal types)

smooth (ASME, EN or JIS): 0.8µm (Ra)

serrated (ASME or JIS): 3.2 to 6.3µm (Ra)

serrated (EN 1092-1 Type B1; up to PN 40): 3.2 to 12.5µm (Ra)

serrated (EN 1092-1 Type D and E): according to standard.

### Electrical connections

Two 1/2 – 14 NPT or M20x1.5 threaded conduit entries, direct on housing.

Special communication connector (on request)

– HART : straight or angle Harting Han 8D connector and one plug.

– FOUNDATION Fieldbus, PROFIBUS PA: M12x1 or 7/8 in.

#### **Terminal block**

HART version: three terminals for signal/external meter wiring up to 2.5 mm<sup>2</sup> (14 AWG), also connection points for test and communication purposes.

Fieldbus versions: two terminals for signal wiring (bus connection) up to 2.5 mm<sup>2</sup> (14 AWG)

#### **Grounding**

Internal and external 6 mm<sup>2</sup> (10 AWG) ground termination points are provided.

#### **Mounting position**

Transmitter can be mounted in any position.

Electronics housing may be rotated to any position. A positive stop prevents over travel.

#### **Mass (without options)**

7 kg to 50 kg approx (15 to 110 lb) according to specified seal(s) options; add 1.5 kg (3.4 lb) for AISI housing.

Add 650 g (1.5 lb) for packing.

#### **Packing**

Carton

(\*) Wetted parts of the transmitter.

(\*\*) Bolts and nuts, gasket and mating flange supplied by customer.

(\*\*\*) Gasket to process supplied by customer.

# Model 266DDH Differential

## Model 266HDH Gauge

## Model 266NDH Absolute

### Configuration

#### Transmitter with HART communication and 4 to 20 mA

##### Standard configuration

Transmitters are factory calibrated to customer's specified range. Calibrated range and tag number are stamped on the tag plate. If a calibration range and tag data are not specified, the transmitter will be supplied with the plate left blank and configured as follows:

Engineering Unit	kPa
4 mA	Zero
20 mA	Upper Range Limit (URL)
Output	Linear
Damping	1 s
Transmitter failure mode	Upscale
Software tag (8 characters max)	Blank
Optional LCD display	PV in kPa; output in mA and in percentage on bargraph

Any or all the above configurable parameters, including Lower range-value and Upper range-value which must be the same unit of measure, can be easily changed using the HART hand-held communicator or by a PC running the configuration software with DTM for 266 models. The transmitter database is customized with specified flange type and material, O-ring and drain/vent materials and meter code option.

##### Custom configuration (option)

The following data may be specified in addition to the standard configuration parameters:

Descriptor	16 alphanumeric characters
Message	32 alphanumeric characters
Date	Day, month, year

For HART protocol available engineering units of pressure measure are :

Pa, kPa, MPa

inH<sub>2</sub>O@4 °C, mmH<sub>2</sub>O@4 °C, psi

inH<sub>2</sub>O@20 °C, ftH<sub>2</sub>O@20 °C, mmH<sub>2</sub>O@20 °C

inHg, mmHg, Torr

g/cm<sup>2</sup>, kg/cm<sup>2</sup>, atm

mbar, bar

These and others are available for PROFIBUS and FOUNDATION Fieldbus.

#### Transmitter with PROFIBUS PA communication

##### Standard configuration

Transmitters are factory calibrated to customer's specified range. Calibrated range and tag number are stamped on the tag plate. If a calibration range and tag data are not specified, the transmitter will be supplied with the plate left blank and configured as follows:

Measure Profile	Pressure
Engineering Unit	kPa
Output scale 0 %	Lower Range Limit (LRL)
Output scale 100 %	Upper Range Limit (URL)
Output	Linear
Hi-Hi Limit	Upper Range Limit (URL)
Hi Limit	Upper Range Limit (URL)
Low Limit	Lower Range Limit (LRL)
Low-Low Limit	Lower Range Limit (LRL)
Limits hysteresis	0.5 % of output scale
PV filter	0 s
Address (set by local key)	126
Tag	32 alphanumeric characters
Optional LCD display	PV in kPa; output in percentage on bargraph

Any or all the above configurable parameters, including the range values which must be the same unit of measure, can be easily changed by a PC running the configuration software with DTM for 266 models. The transmitter database is customized with specified flange type and material, O-ring and drain/vent materials and meter code option.

##### Custom configuration (option)

The following data may be specified in addition to the standard configuration parameters:

Descriptor	32 alphanumeric characters
Message	32 alphanumeric characters
Date	Day, month, year

## Transmitter with FOUNDATION Fieldbus communication

### Standard configuration

Transmitters are factory calibrated to customer's specified range. Calibrated range and tag number are stamped on the tag plate. If a calibration range and tag data are not specified, the transmitter will be supplied with the plate left blank and the analog input function block FB1 is configured as follows:

Measure Profile	Pressure
Engineering Unit	kPa
Output scale 0 %	Lower Range Limit (LRL)
Output scale 100 %	Upper Range Limit (URL)
Output	Linear
Hi-Hi Limit	Upper Range Limit (URL)
Hi Limit :	Upper Range Limit (URL)
Low Limit	Lower Range Limit (LRL)
Low-Low Limit	Lower Range Limit (LRL)
Limits hysteresis	0.5 % of output scale
PV filter time	0 s
Tag	32 alphanumeric characters
Optional LCD display	PV in kPa; output in percentage on bargraph

The analog input function block FB2 and FB3 are configured respectively for the sensor temperature measured in °C and for the static pressure measured in MPa.

Any or all the above configurable parameters, including the range values, can be changed using any host compliant to FOUNDATION fieldbus. The transmitter database is customized with specified flange type and material, O-ring and drain/vent materials and meter code option.

Model 266DDH Differential  
 Model 266HDH Gauge  
 Model 266NDH Absolute

MOUNTING DIMENSIONS (not for construction unless certified) – dimensions in mm (in.)

266DDH with barrel housing and direct mount seal S26RA/S26RE/S26RJ rotating flange Raised Face flush diaphragm

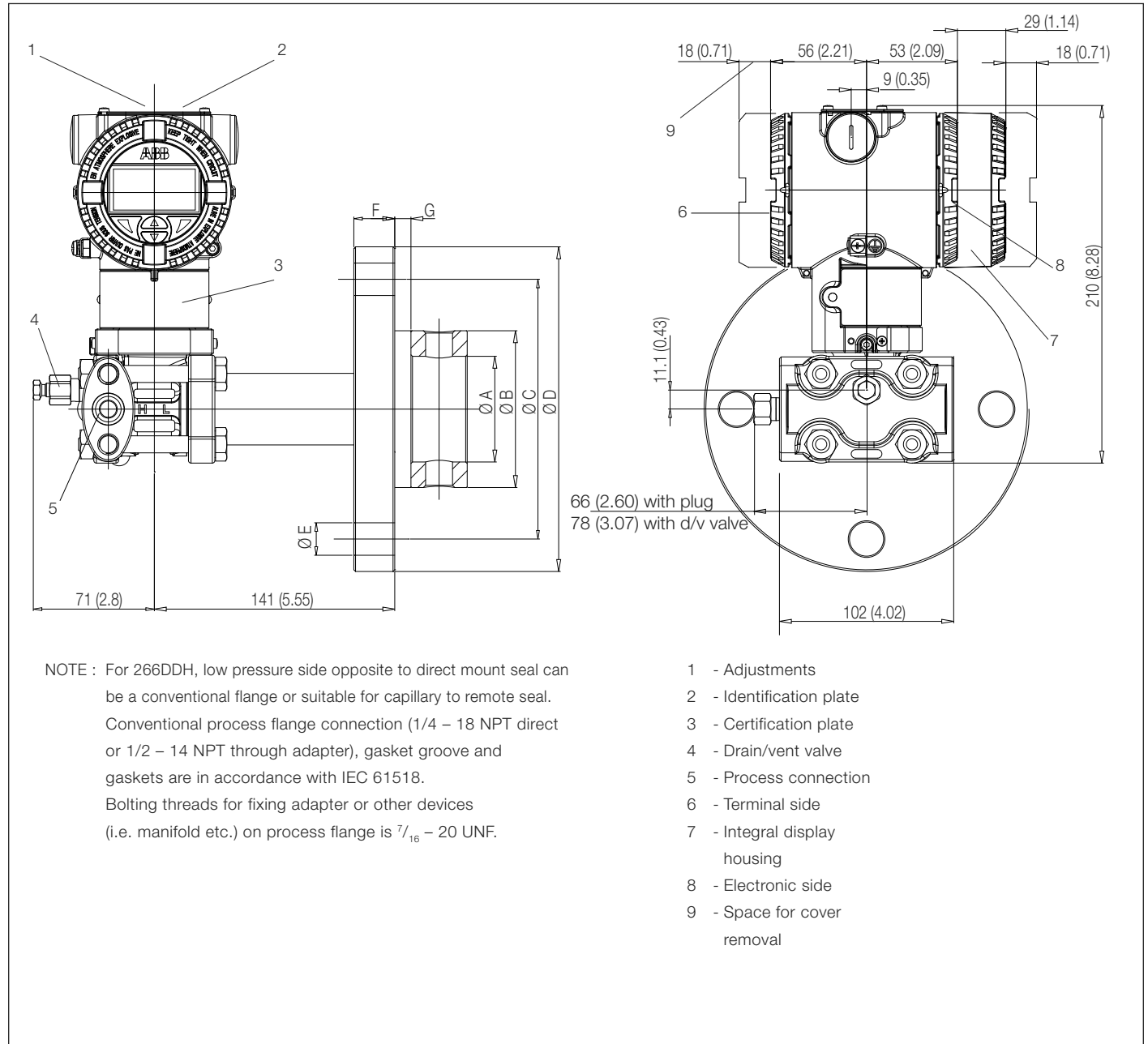

266DDH with DIN housing and direct mount seal S26RA/S26RE rotating flange Raised Face extended diaphragm

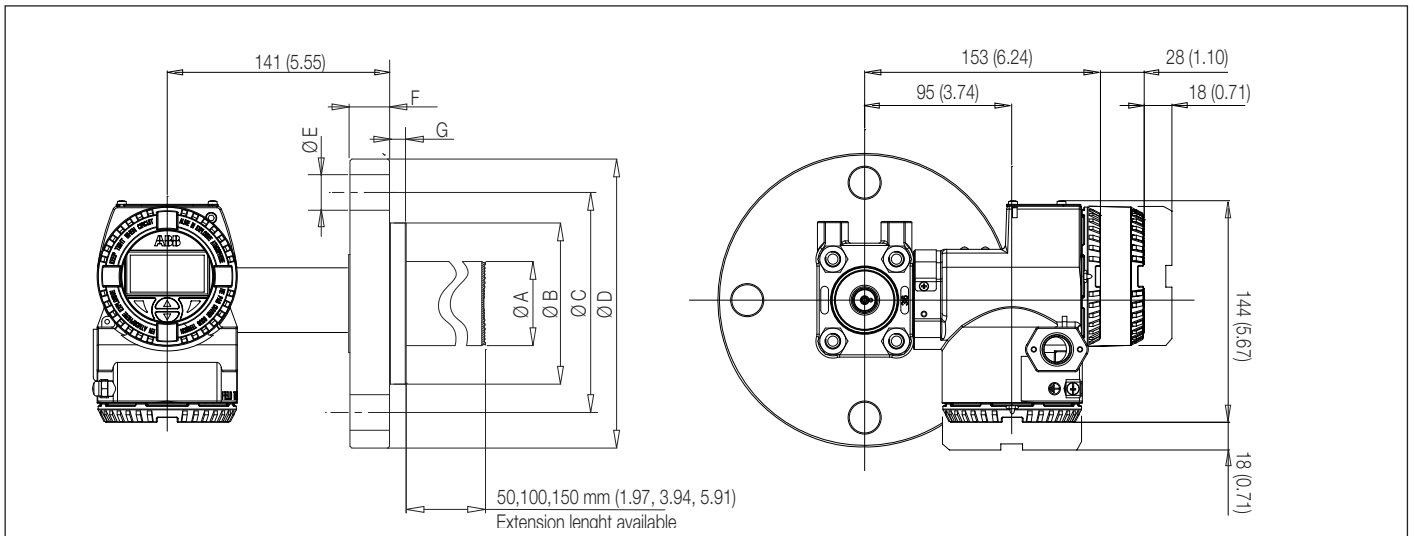

266HDH/266NDH with barrel housing and direct mount seal S26RA/S26RE flanged Raised Face extended diaphragm

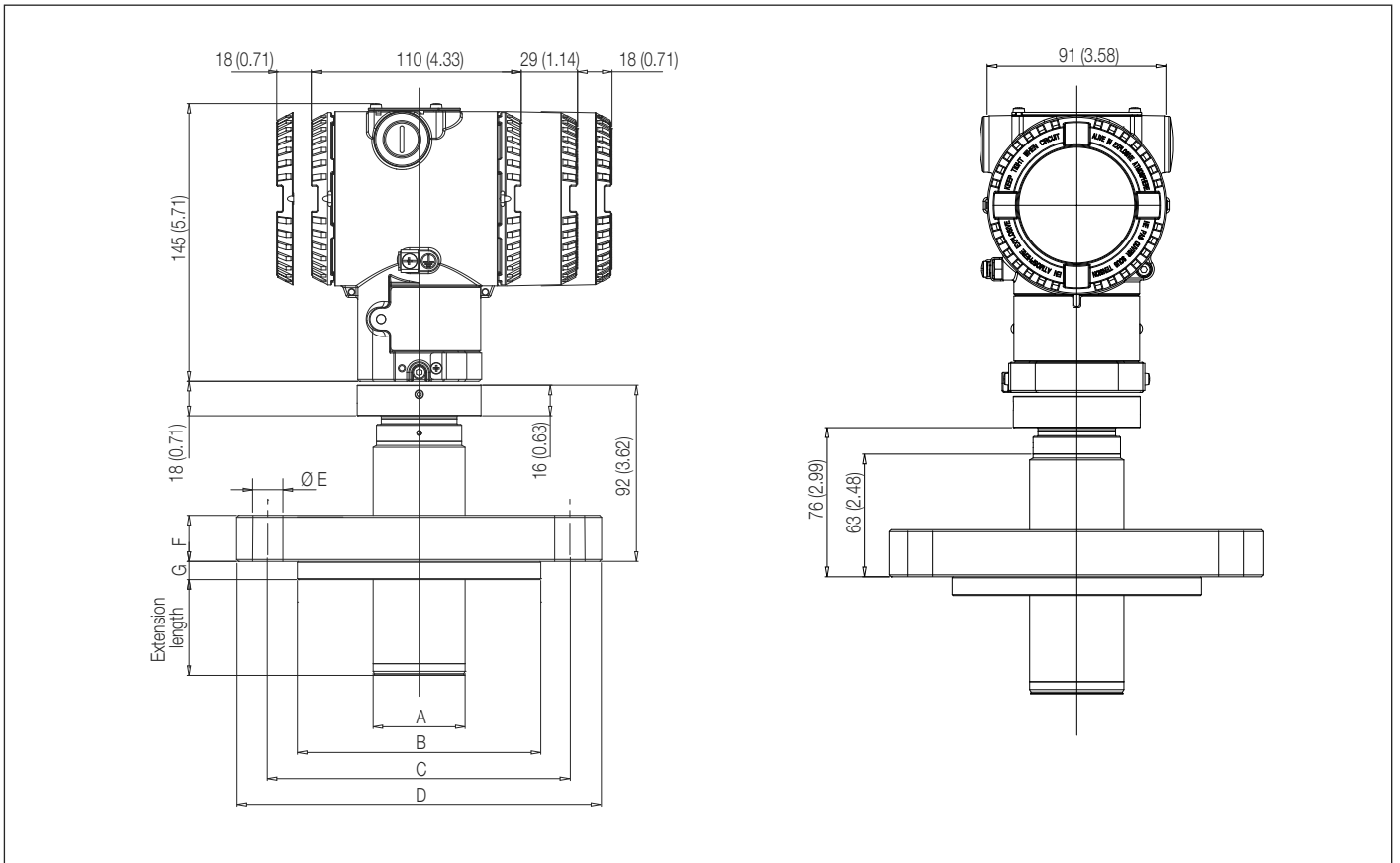

Model 266DDH Differential  
 Model 266HDH Gauge  
 Model 266NDH Absolute

Size/Rating	Dimensions mm (in) for S26RA										
	A (dia)				B (dia)	C (dia)	D (dia)	E (dia)	F	G	N° of holes
	extended diaphragm	flush diaphragm		flushing ring internal dia							
		std.	low thick.								
2 in. ASME CL 150	48 (1.9)	60 (2.36)	58 (2.28)	62 (2.44)	92 (3.62)	120.65 (4.75)	152.4 (6)	19.1 (0.79)	17.5 (0.6)	9.5 (0.37)	4
2 in. ASME CL 300	48 (1.9)	60 (2.36)	58 (2.28)	62 (2.44)	92 (3.62)	127 (5)	165.1 (6.5)	19.1 (0.79)	20.8 (0.8)	9.5 (0.37)	8
2 in. ASME CL 600	NA	60 (2.36)	58 (2.28)	62 (2.44)	92 (3.62)	127 (5)	165.1 (6.5)	19.1 (0.79)	25.4 (1)	9.5 (0.37)	8
2 in. ASME CL 900	NA	60 (2.36)	58 (2.28)	62 (2.44)	92 (3.62)	165 (6.5)	215.9 (8.5)	26 (1.02)	38.1 (1.5)	9.5 (0.37)	8
2 in. ASME CL 1500	NA	60 (2.36)	58 (2.28)	62 (2.44)	92 (3.62)	165 (6.5)	215.9 (8.5)	26 (1.02)	38.1 (1.5)	9.5 (0.37)	8
3 in. ASME CL 150	72 (2.83)	89 (3.5)	75 (2.95)	92 (3.62)	127 (5)	152.4 (6)	190.5 (7.5)	19.1 (0.79)	22.4 (0.88)	9.5 (0.37)	4
3 in. ASME CL 300	72 (2.83)	89 (3.5)	75 (2.95)	92 (3.62)	127 (5)	168.15 (6.62)	209.6 (8.25)	22.4 (0.88)	26.9 (1.1)	9.5 (0.37)	8
3 in. ASME CL 600	NA	89 (3.5)	75 (2.95)	92 (3.62)	127 (5)	168.15 (6.62)	209.6 (8.25)	22.4 (0.88)	31.8 (1.3)	9.5 (0.37)	8
3 in. ASME CL 900	NA	89 (3.5)	75 (2.95)	92 (3.62)	127 (5)	190.5 (7.5)	241 (9.48)	26 (1.02)	38.1 (1.5)	9.5 (0.37)	8
3 in. ASME CL1500	NA	89 (3.5)	75 (2.95)	92 (3.62)	127 (5)	203.2 (8)	266.7 (10.5)	31.75 (1.25)	47.7 (1.88)	9.5 (0.37)	8
4 in. ASME CL 150	94 (3.7)	89 (3.5)	75 (2.95)	92 (3.62)	157.2 (6.2)	190.5 (7.5)	228.6 (9)	19.1 (0.79)	22.4 (0.88)	9.5 (0.37)	8
4 in. ASME CL 300	94 (3.7)	89 (3.5)	75 (2.95)	92 (3.62)	157.2 (6.2)	200.2 (7.88)	254 (10)	22 (0.86)	30.2 (1.19)	9.5 (0.37)	8

Size/Rating	Dimensions mm (in) for S26RE										
	A (dia)				B (dia)	C (dia)	D (dia)	E (dia)	F	G	N° of holes
	extended diaphragm	flush diaphragm		flushing ring internal dia							
		std.	low thick.								
DN 50 EN PN 16	48 (1.9)	60 (2.36)	58 (2.28)	62 (2.44)	102 (4.02)	125 (4.92)	165 (6.5)	18 (0.71)	15 (0.58)	9.5 (0.37)	4
DN 50 EN PN 40	48 (1.9)	60 (2.36)	58 (2.28)	62 (2.44)	102 (4.02)	125 (4.92)	165 (6.5)	18 (0.71)	18 (0.67)	9.5 (0.37)	4
DN 50 EN PN 63	NA	60 (2.36)	58 (2.28)	62 (2.44)	102 (4.02)	135 (5.31)	180 (7.08)	22 (0.86)	23 (0.9)	9.5 (0.37)	4
DN 50 EN PN 100	NA	60 (2.36)	58 (2.28)	62 (2.44)	102 (4.02)	145 (5.71)	195 (7.67)	26 (1.02)	27 (1.06)	9.5 (0.37)	4
DN 80 EN PN 16	72 (2.83)	89 (3.5)	75 (2.95)	92 (3.62)	138 (5.43)	160 (6.3)	200 (7.87)	18 (0.71)	17 (0.67)	9.5 (0.37)	8
DN 80 EN PN 40	72 (2.83)	89 (3.5)	75 (2.95)	92 (3.62)	138 (5.43)	160 (6.3)	200 (7.87)	18 (0.71)	21 (0.83)	9.5 (0.37)	8
DN 80 EN PN 63	NA	89 (3.5)	75 (2.95)	92 (3.62)	138 (5.43)	170 (6.7)	215 (8.46)	22 (0.86)	25 (0.98)	9.5 (0.37)	8
DN 80 EN PN 100	NA	89 (3.5)	75 (2.95)	92 (3.62)	138 (5.43)	180 (7.08)	230 (9.05)	26 (1.02)	33 (1.3)	9.5 (0.37)	8
DN 100 EN PN 16	94 (3.7)	89 (3.5)	75 (2.95)	92 (3.62)	158 (6.22)	180 (7.08)	220 (8.66)	18 (0.71)	17 (0.67)	9.5 (0.37)	8
DN 100 EN PN 40	94 (3.7)	89 (3.5)	75 (2.95)	92 (3.62)	162 (6.38)	190 (7.48)	235 (9.25)	22 (0.86)	21 (0.83)	9.5 (0.37)	8

Size/Rating	Dimensions mm (in) for S26RJ							
	A (dia) flush diaphragm	B (dia)	C (dia)	D (dia)	E (dia)	F	G	N° of holes
A50 Class 10K	60 (2.36)	96 (3.78)	120 (4.72)	155 (6.1)	19 (0.75)	16 (0.63)	9.5 (0.37)	4
A50 Class 20K	60 (2.36)	96 (3.78)	120 (4.72)	155 (6.1)	19 (0.75)	18 (0.71)	9.5 (0.37)	8
A50 Class 40K	60 (2.36)	104.3 (4.11)	130 (5.12)	165 (6.5)	19 (0.75)	26 (1.02)	9.5 (0.37)	8
A80 Class 10K	89 (3.5)	126 (4.96)	150 (5.91)	185 (7.28)	19 (0.75)	18 (0.71)	9.5 (0.37)	8
A80 Class 20K	89 (3.5)	132 (5.2)	160 (6.3)	200 (7.87)	23 (0.91)	22 (0.87)	9.5 (0.37)	8
A80 Class 40K	89 (3.5)	139.4 (5.49)	170 (6.69)	210 (8.27)	23 (0.91)	32 (1.26)	9.5 (0.37)	8
A100 Class 10K	89 (3.5)	151 (5.94)	175 (6.89)	210 (8.27)	19 (0.75)	18 (0.71)	9.5 (0.37)	8
A100 Class 20K	89 (3.5)	160 (6.3)	185 (7.28)	225 (8.86)	23 (0.91)	24 (0.94)	9.5 (0.37)	8

266DDH with barrel housing and direct mount seal S26FA/S26FE fixed flange Raised Face flush diaphragm

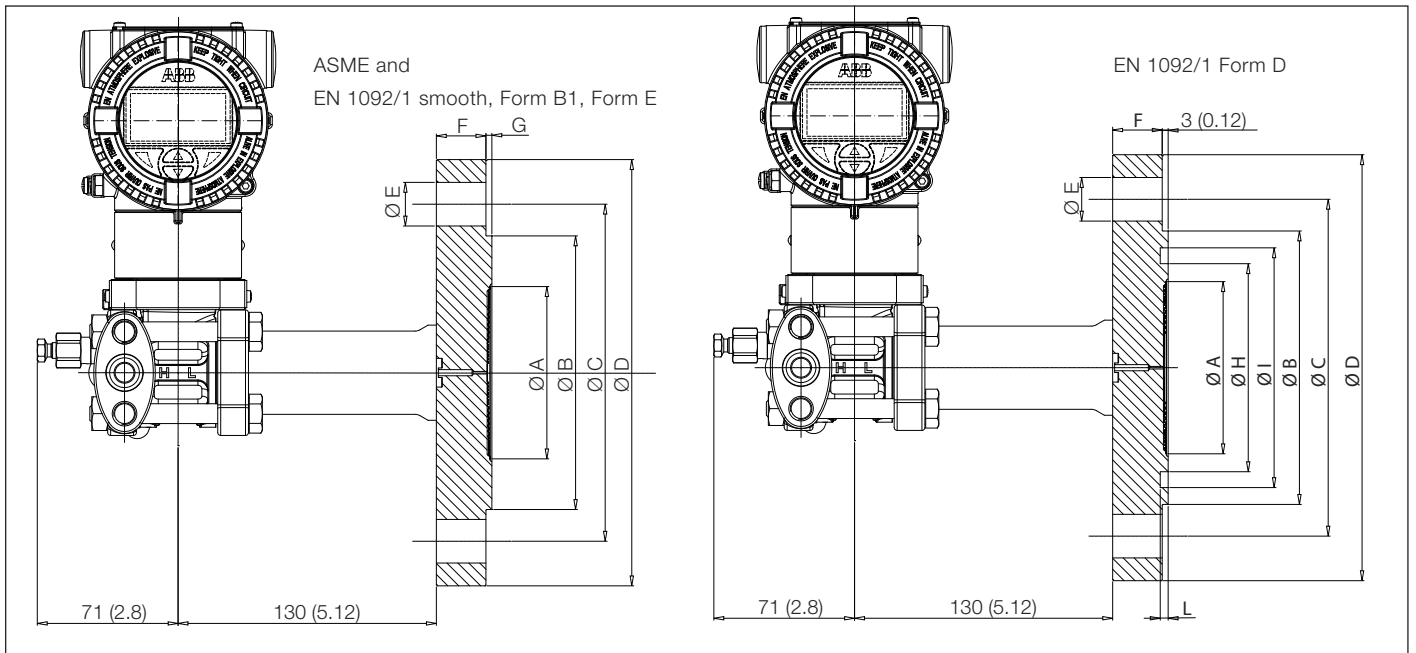

266HDH/266NDH with barrel housing and direct mount seal S26FA/S26FE flanged Raised Face flush diaphragm

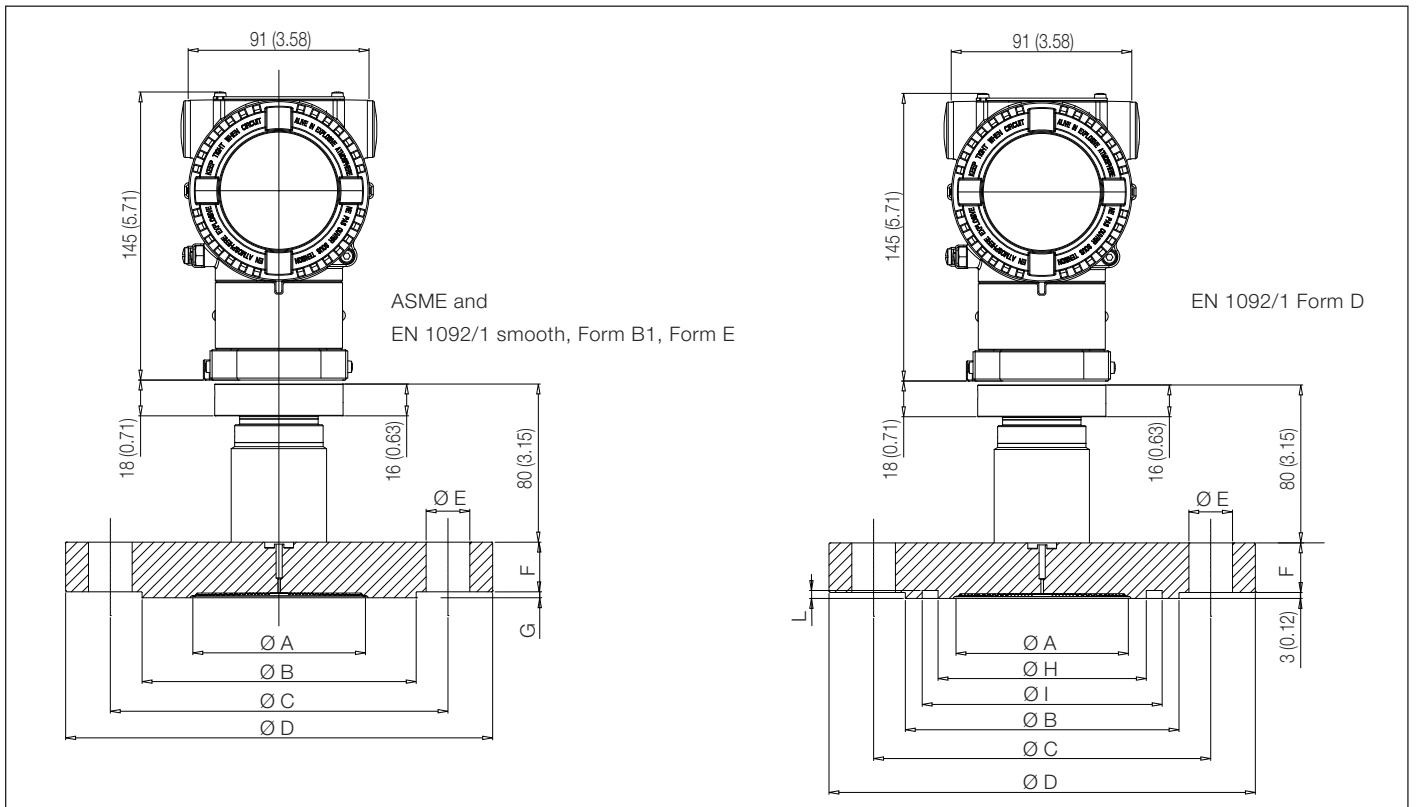

Model 266DDH Differential  
 Model 266HDH Gauge  
 Model 266NDH Absolute

Size/Rating	Dimensions mm (in) for S26FA									
	A (dia)			B (dia)	C (dia)	D (dia)	E (dia)	F	G	N° of holes
	std. thickness diaphragm	low thickness diaphragm	flushing ring internal dia							
2 in. ASME CL 150	60 (2.36)	58 (2.28)	62 (2.44)	92 (3.62)	120.65 (4.75)	152.4 (6)	19.1 (0.79)	17.5 (0.6)	2 (0.08)	4
2 in. ASME CL 300	60 (2.36)	58 (2.28)	62 (2.44)	92 (3.62)	127 (5)	165.1 (6.5)	19.1 (0.79)	20.8 (0.8)	2 (0.08)	8
2 in. ASME CL 600	60 (2.36)	58 (2.28)	62 (2.44)	92 (3.62)	127 (5)	165.1 (6.5)	19.1 (0.79)	25.4 (1)	7 (0.27)	8
3 in. ASME CL 150	89 (3.5)	75 (2.95)	92 (3.62)	127 (5)	152.4 (6)	190.5 (7.5)	19.1 (0.79)	22.4 (0.88)	2 (0.08)	4
3 in. ASME CL 300	89 (3.5)	75 (2.95)	92 (3.62)	127 (5)	168.15 (6.62)	209.6 (8.25)	22.4 (0.86)	26.9 (1.1)	2 (0.08)	8
3 in. ASME CL 600	89 (3.5)	75 (2.95)	92 (3.62)	127 (5)	168.15 (6.62)	209.6 (8.25)	22.4 (0.86)	31.8 (1.3)	7 (0.27)	8
4 in. ASME CL 150	89 (3.5)	75 (2.95)	92 (3.62)	157.2 (6.2)	190.5 (7.5)	228.6 (9)	19.1 (0.79)	22.4 (0.88)	2 (0.08)	8

Size/Rating	Dimensions mm (in) for S26FE smooth and Form B1									
	A (dia)			B (dia)	C (dia)	D (dia)	E (dia)	F	G	N° of holes
	std. thickness diaphragm	low thickness diaphragm	flushing ring internal dia							
DN 50 EN PN 16	60 (2.36)	58 (2.28)	62 (2.44)	102 (4.02)	125 (4.92)	165 (6.5)	18 (0.71)	15 (0.58)	3 (0.12)	4
DN 50 EN PN 40	60 (2.36)	58 (2.28)	62 (2.44)	102 (4.02)	125 (4.92)	165 (6.5)	18 (0.71)	18 (0.67)	3 (0.12)	4
DN 50 EN PN 63	60 (2.36)	58 (2.28)	62 (2.44)	102 (4.02)	135 (5.31)	180 (7.08)	22 (0.86)	23 (0.9)	3 (0.12)	4
DN 50 EN PN 100	60 (2.36)	58 (2.28)	62 (2.44)	102 (4.02)	145 (5.71)	195 (7.67)	26 (1.02)	27 (1.06)	3 (0.12)	4
DN 80 EN PN 16	89 (3.5)	75 (2.95)	92 (3.62)	138 (5.43)	160 (6.3)	200 (7.87)	18 (0.71)	17 (0.67)	3 (0.12)	8
DN 80 EN PN 40	89 (3.5)	75 (2.95)	92 (3.62)	138 (5.43)	160 (6.3)	200 (7.87)	18 (0.71)	21 (0.83)	3 (0.12)	8
DN 80 EN PN 63	89 (3.5)	75 (2.95)	92 (3.62)	138 (5.43)	170 (6.7)	215 (8.46)	22 (0.86)	25 (0.98)	3 (0.12)	8
DN 80 EN PN 100	89 (3.5)	75 (2.95)	92 (3.62)	138 (5.43)	180 (7.08)	230 (9.05)	26 (1.02)	33 (1.3)	3 (0.12)	8
DN 100 EN PN 16	89 (3.5)	75 (2.95)	92 (3.62)	158 (6.22)	180 (7.08)	220 (8.66)	18 (0.71)	17 (0.67)	3 (0.12)	8

Size/Rating	Dimensions mm (in) for S26FE Form E									
	diaphragm A (dia)		B (dia)	C (dia)	D (dia)	E (dia)	F	G	N° of holes	
	std. thickness	low thickness								
DN 50 EN PN 16	60 (2.36)	58 (2.28)	87 (3.42)	125 (4.92)	165 (6.5)	18 (0.71)	13.5 (0.53)	4.5 (0.18)	4	
DN 50 EN PN 40	60 (2.36)	58 (2.28)	87 (3.42)	125 (4.92)	165 (6.5)	18 (0.71)	15.5 (0.61)	4.5 (0.18)	4	
DN 50 EN PN 63	60 (2.36)	58 (2.28)	87 (3.42)	135 (5.31)	180 (7.08)	22 (0.86)	21.5 (0.85)	4.5 (0.18)	4	
DN 50 EN PN 100	60 (2.36)	58 (2.28)	87 (3.42)	145 (5.71)	195 (7.67)	26 (1.02)	25.5 (1)	4.5 (0.18)	4	
DN 80 EN PN 16	89 (3.5)	75 (2.95)	120 (4.72)	160 (6.3)	200 (7.87)	18 (0.71)	15.5 (0.61)	4.5 (0.18)	8	
DN 80 EN PN 40	89 (3.5)	75 (2.95)	120 (4.72)	160 (6.3)	200 (7.87)	18 (0.71)	19.5 (0.77)	4.5 (0.18)	8	
DN 80 EN PN 63	89 (3.5)	75 (2.95)	120 (4.72)	170 (6.7)	215 (8.46)	22 (0.86)	23.5 (0.92)	4.5 (0.18)	8	
DN 80 EN PN 100	89 (3.5)	75 (2.95)	120 (4.72)	180 (7.08)	230 (9.05)	26 (1.02)	31.5 (1.24)	4.5 (0.18)	8	
DN 100 EN PN 16	89 (3.5)	75 (2.95)	149 (5.87)	180 (7.08)	220 (8.66)	18 (0.71)	15 (0.59)	5 (0.20)	8	

Size/Rating	Dimensions mm (in) for S26FE Form D										
	diaphragm A (dia)		B (dia)	C (dia)	D (dia)	E (dia)	F	H (dia)	I (dia)	L	N° of holes
	std. thickness	low thickness									
DN 50 EN PN 16	60 (2.36)	58 (2.28)	102 (4.02)	125 (4.92)	165 (6.5)	18 (0.71)	15 (0.59)	72 (2.83)	88 (3.46)	4 (0.16)	4
DN 50 EN PN 40	60 (2.36)	58 (2.28)	102 (4.02)	125 (4.92)	165 (6.5)	18 (0.71)	18 (0.71)	72 (2.83)	88 (3.46)	4 (0.16)	4
DN 50 EN PN 63	60 (2.36)	58 (2.28)	102 (4.02)	135 (5.31)	180 (7.08)	22 (0.86)	23 (0.91)	72 (2.83)	88 (3.46)	4 (0.16)	4
DN 50 EN PN 100	60 (2.36)	58 (2.28)	102 (4.02)	145 (5.71)	195 (7.67)	26 (1.02)	27 (1.06)	72 (2.83)	88 (3.46)	4 (0.16)	4
DN 80 EN PN 16	89 (3.5)	75 (2.95)	138 (5.43)	160 (6.3)	200 (7.87)	18 (0.71)	17 (0.67)	105 (4.13)	121 (4.76)	4 (0.16)	8
DN 80 EN PN 40	89 (3.5)	75 (2.95)	138 (5.43)	160 (6.3)	200 (7.87)	18 (0.71)	21 (0.83)	105 (4.13)	121 (4.76)	4 (0.16)	8
DN 80 EN PN 63	89 (3.5)	75 (2.95)	138 (5.43)	170 (6.7)	215 (8.46)	22 (0.86)	25 (0.92)	105 (4.13)	121 (4.76)	4 (0.16)	8
DN 80 EN PN 100	89 (3.5)	75 (2.95)	138 (5.43)	180 (7.08)	230 (9.05)	26 (1.02)	33 (1.3)	105 (4.13)	121 (4.76)	4 (0.16)	8
DN 100 EN PN 16	89 (3.5)	75 (2.95)	158 (6.22)	180 (7.08)	220 (8.66)	18 (0.71)	17 (0.67)	128 (5.04)	149 (5.91)	4.5 (0.18)	8

266DDH with barrel housing and direct mount seal S26RR flanged Ring Joint flush diaphragm

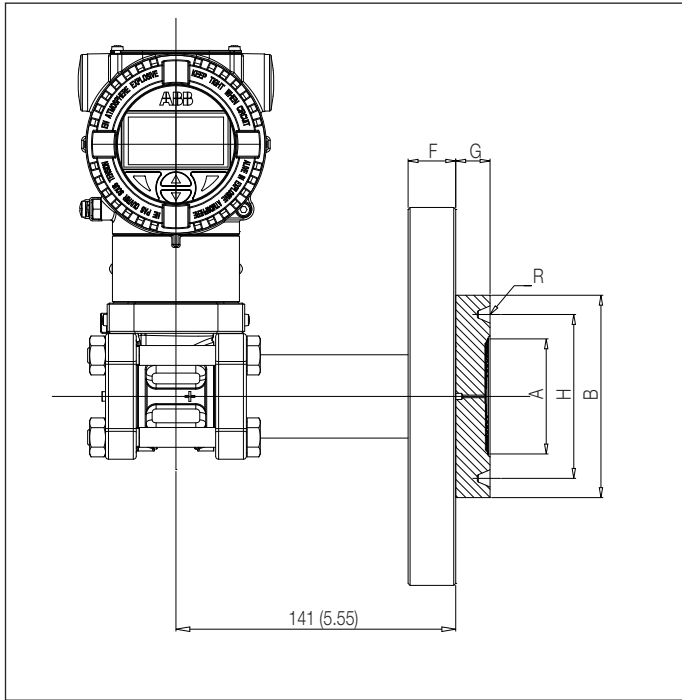

266HDH / 266NDH with barrel housing and direct mount seal S26RR flanged Ring Joint flush diaphragm

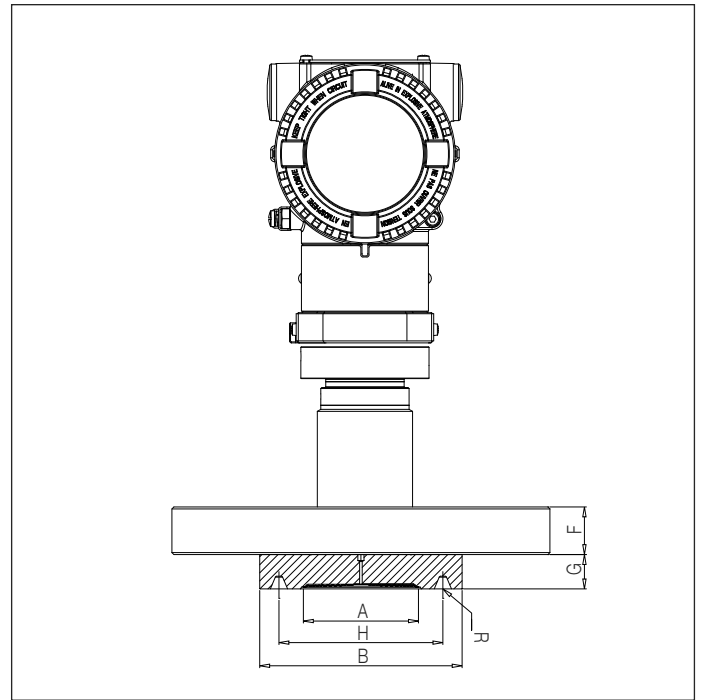

Size/Rating	Dimensions mm (in) for S26RR									N° of holes
	A (dia)	B (dia)	C (dia)	D (dia)	E (dia)	F	G	H (dia)	R	
1-1/2 in. ASME CL 150	48 (1.89)	83 (3.27)	98.6 (3.88)	127 (5)	15.75 (0.62)	17.5 (0.69)	17.3 (0.68)	65.1 (2.56)	R19	4
1-1/2 in. ASME CL 300	48 (1.89)	90 (3.54)	114.3 (4.5)	155.5 (6.12)	22.35 (0.88)	20.6 (0.81)	17.3 (0.68)	68.3 (2.69)	R20	4
1-1/2 in. ASME CL 600	48 (1.89)	90 (3.54)	114.3 (4.5)	155.5 (6.12)	22.35 (0.88)	22.4 (0.88)	17.3 (0.68)	68.3 (2.69)	R20	4
1-1/2 in. ASME CL 900/1500	48 (1.89)	92 (3.62)	124 (4.88)	177.8 (7)	28.45 (1.12)	31.8 (1.25)	20.8 (0.82)	68.3 (2.69)	R20	4
2 in. ASME CL 150	60 (2.36)	102 (4.02)	120.65 (4.75)	152.4 (6)	19.05 (0.75)	19.05 (0.75)	17.3 (0.68)	82.6 (3.25)	R22	4
2 in. ASME CL 300	60 (2.36)	108 (4.25)	127 (5)	165.1 (6.5)	19.05 (0.75)	22.35 (0.88)	17.3 (0.68)	82.6 (3.25)	R23	8
2 in. ASME CL 600	60 (2.36)	108 (4.25)	127 (5)	165.1 (6.5)	19.05 (0.75)	25.4 (1)	17.3 (0.68)	82.6 (3.25)	R23	8
2 in. ASME CL 900/1500	60 (2.36)	124 (4.88)	165 (6.5)	215.9 (8.5)	25.4 (1)	38.1 (1.5)	20.8 (0.82)	95.3 (3.75)	R24	8
3 in. ASME CL 150	89 (3.5)	133 (5.24)	152.4 (6)	190.5 (7.5)	19.05 (0.75)	23.87 (0.94)	17.3 (0.68)	114.3 (4.5)	R29	4
3 in. ASME CL 300	89 (3.5)	146 (5.75)	168.15 (6.62)	209.55 (8.25)	22.35 (0.88)	28.44 (1.12)	17.3 (0.68)	123.8 (4.87)	R31	8
3 in. ASME CL 600	89 (3.5)	146 (5.75)	168.15 (6.62)	209.55 (8.25)	22.35 (0.88)	31.75 (1.25)	17.3 (0.68)	123.8 (4.87)	R31	8
3 in. ASME CL 900	89 (3.5)	155 (6.10)	190.5 (7.5)	241.3 (9.5)	25.4 (1)	38.1 (1.50)	20.8 (0.82)	123.8 (4.87)	R31	8
3 in. ASME CL 1500	89 (3.5)	168 (6.61)	203.2 (8)	266.7 (10.5)	31.75 (1.25)	47.8 (1.88)	20.8 (0.82)	136.5 (5.37)	R35	8

# Model 266DDH Differential

## Model 266HDH Gauge

## Model 266NDH Absolute

266DDH with barrel housing and direct mount seal S26Mx off-line flanged

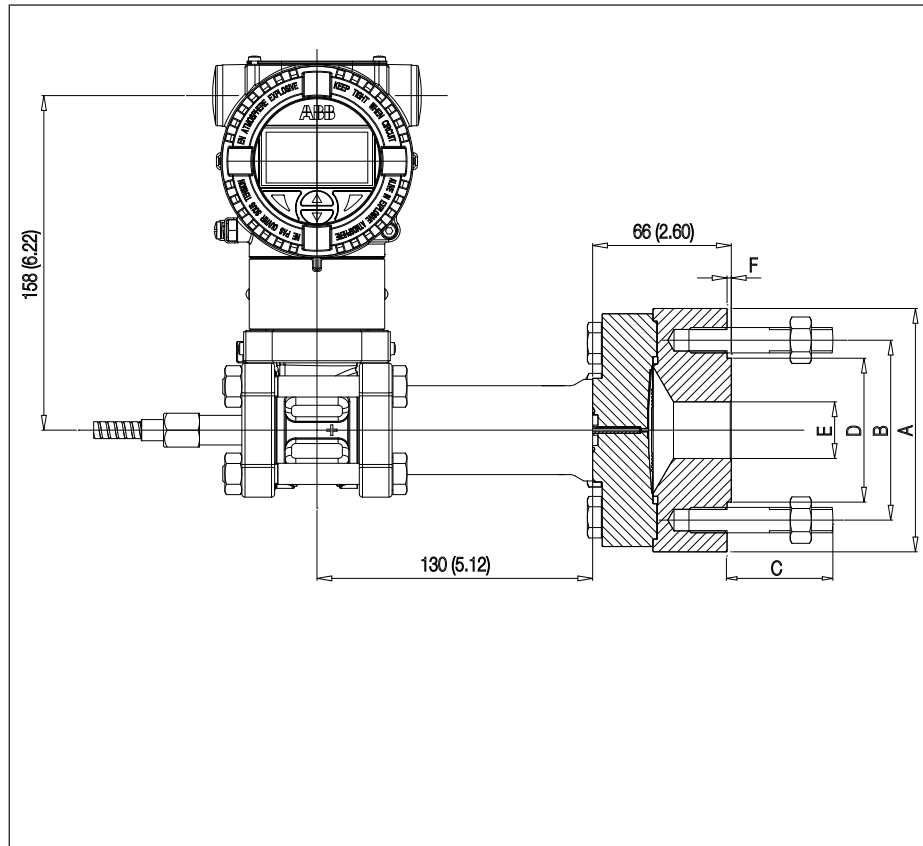

266HDH / 266NDH with barrel housing and direct mount seal S26Mx off-line flanged

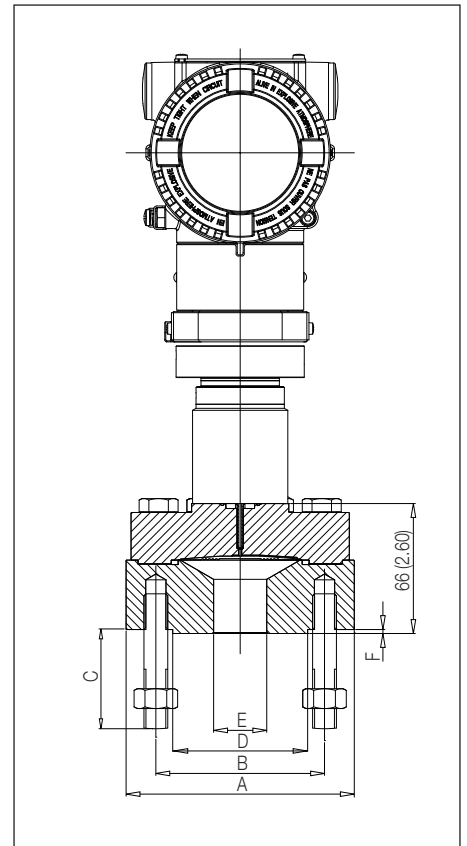

Size/Rating	Dimensions mm (in) for S26MA and S26ME						
	A (dia)	B (dia)	C (4 studs)		D (dia)	E (dia)	F
			Length	Thread			
1/2 in. ASME CL 150	110 (4.33)	60.5 (2.38)	39 (1.53)	1/2in – 13 UNC	35.1 (1.38)	15.8 (0.62)	1.6 (0.06)
1/2 in. ASME CL 300	110 (4.33)	66.5 (2.62)	39 (1.53)	1/2in – 13 UNC	35.1 (1.38)	15.8 (0.62)	1.6 (0.06)
1 in. ASME CL 150	110 (4.33)	79.4 (3.12)	39 (1.53)	1/2in – 13 UNC	50.8 (2)	26.7 (1.05)	1.6 (0.06)
1 in. ASME CL 300	124 (4.88)	88.9 (3.5)	51 (2)	5/8in – 11 UNC	50.8 (2)	26.7 (1.05)	1.6 (0.06)
1 1/2 in. ASME CL 150	127 (5)	98.4 (3.87)	39 (1.53)	1/2in – 13 UNC	73 (2.87)	41 (1.61)	1.6 (0.06)
1 1/2 in. ASME CL 300	155 (6.1)	114.3 (4.5)	57 (2.24)	3/4in – 10 UNC	73 (2.87)	41 (1.61)	1.6 (0.06)
DN 25 PN 16-40	115 (4.52)	85 (3.34)	42 (1.65)	M12	68 (2.67)	28.5 (1.12)	2 (0.08)
DN 40 PN 16-40	150 (5.9)	110 (4.33)	48 (1.89)	M16	88 (3.46)	43.1 (1.69)	3 (0.12)

266DDH with barrel housing and direct mount seal S26TT off-line threaded flange

266HDH / 266NDH with barrel housing and direct mount seal S26TT off-line threaded flange

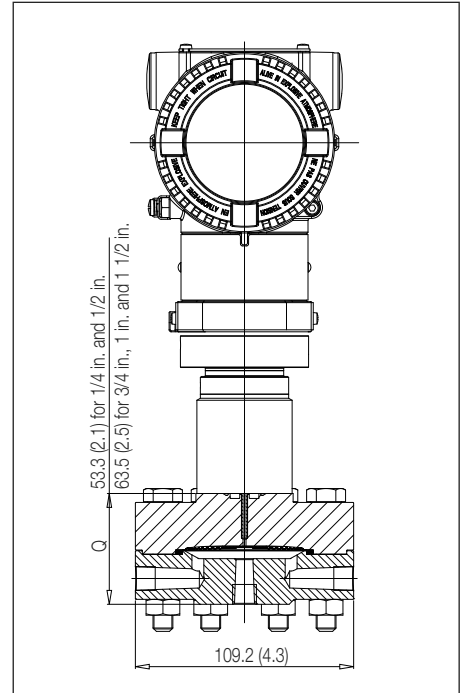
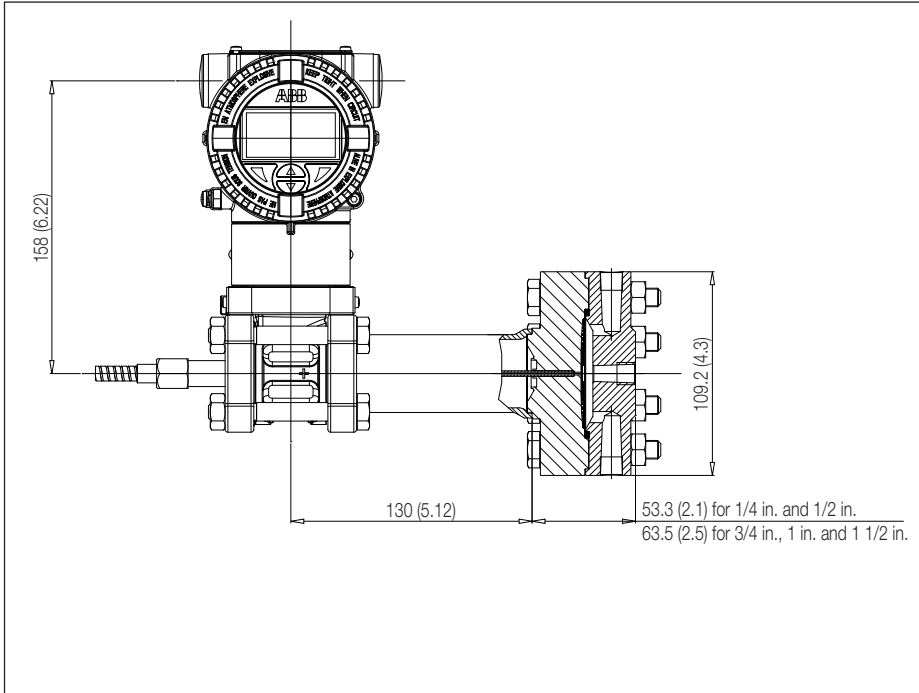

266HDH / 266NDH with barrel housing and direct mount seal S26JN in-line

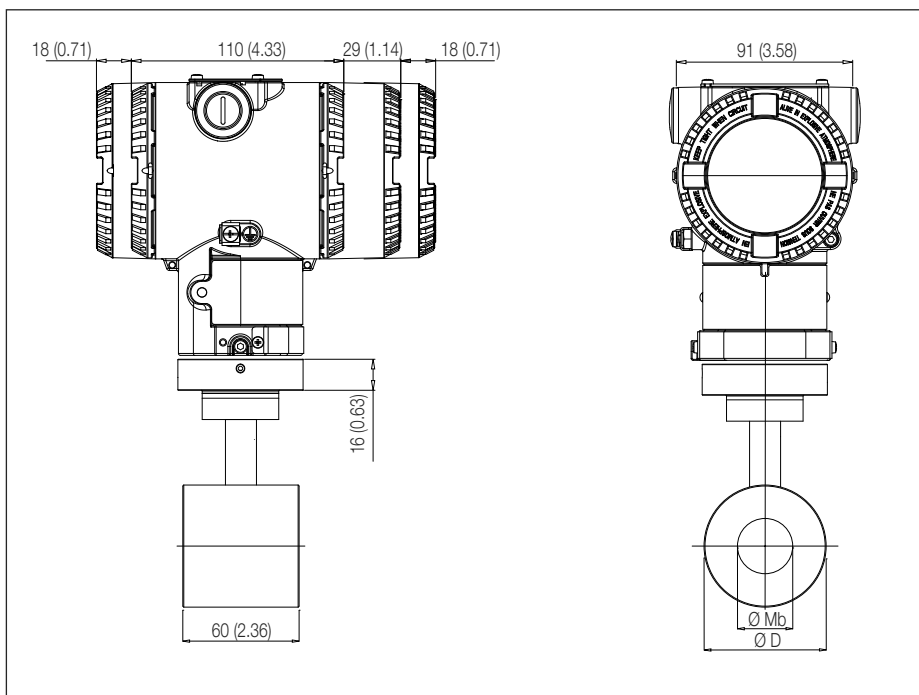

Dimensions mm (in) for S26JN		
Size/Rating	D (dia)	Mb (dia)
1 in. / DN 25	63 (2.48)	28.5 (1.12)
1 1/2 in. / DN 40	85 (3.35)	43 (1.69)
2 in. / DN 50	95 (3.74)	54.5 (2.15)
3 in. / DN 80	130 (5.12)	82.5 (3.25)

Model 266DDH Differential  
 Model 266HDH Gauge  
 Model 266NDH Absolute

266DDH with barrel housing and direct mount seal S26SS Triclamp

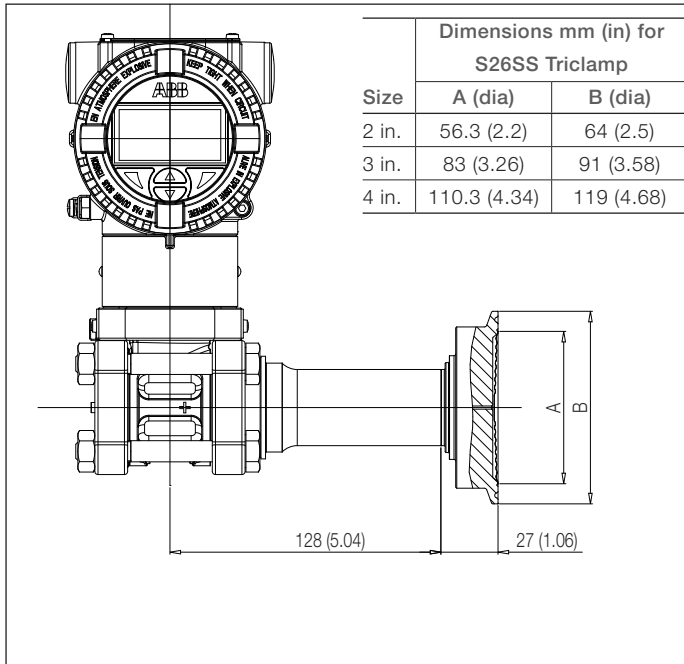

266HDH / 266NDH with barrel housing and direct mount seal S26SS Triclamp

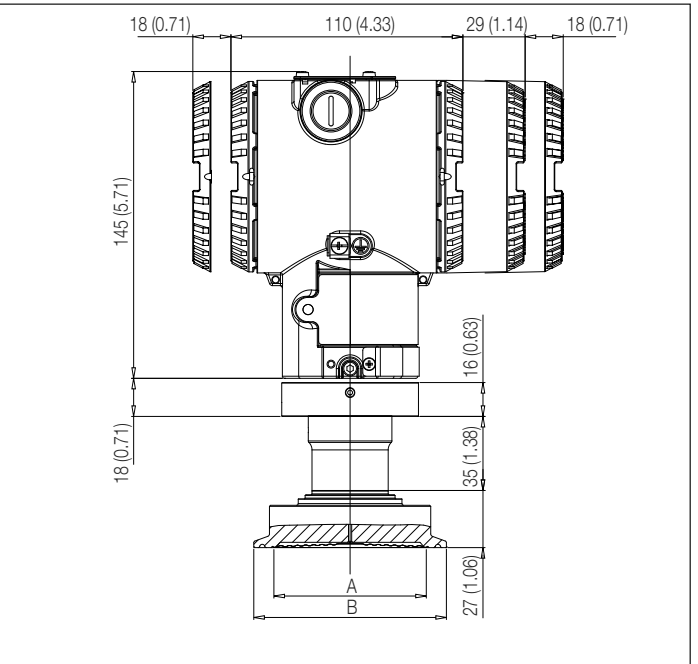

266DDH with barrel housing and direct mount seal S26SS Union Nut

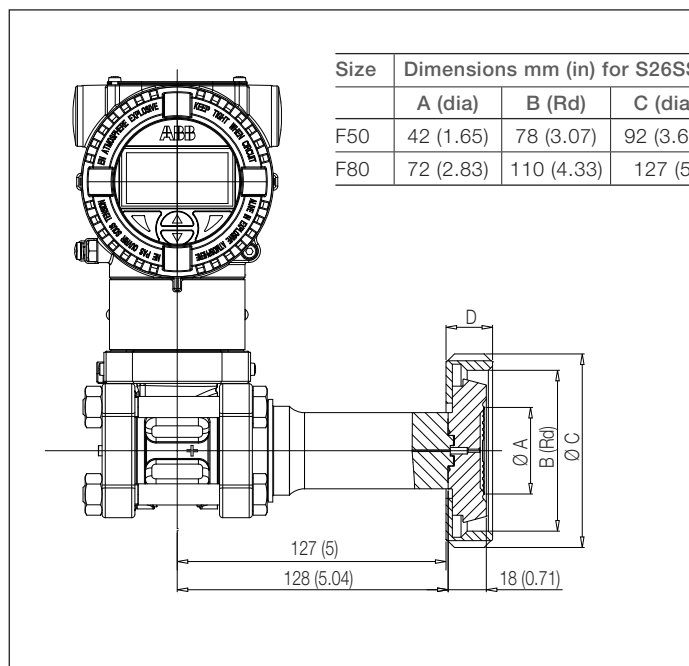

266HDH / 266NDH with barrel housing and direct mount seal S26SS Union Nut

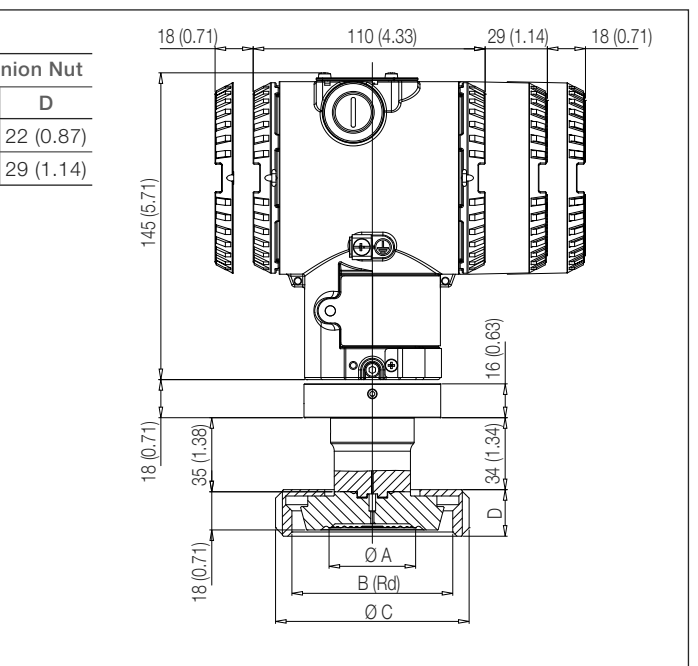

266DDH with barrel housing and direct mount seal S26SS Cherry Burrell

266HDH / 266NDH with barrel housing and direct mount seal S26SS Cherry Burrell

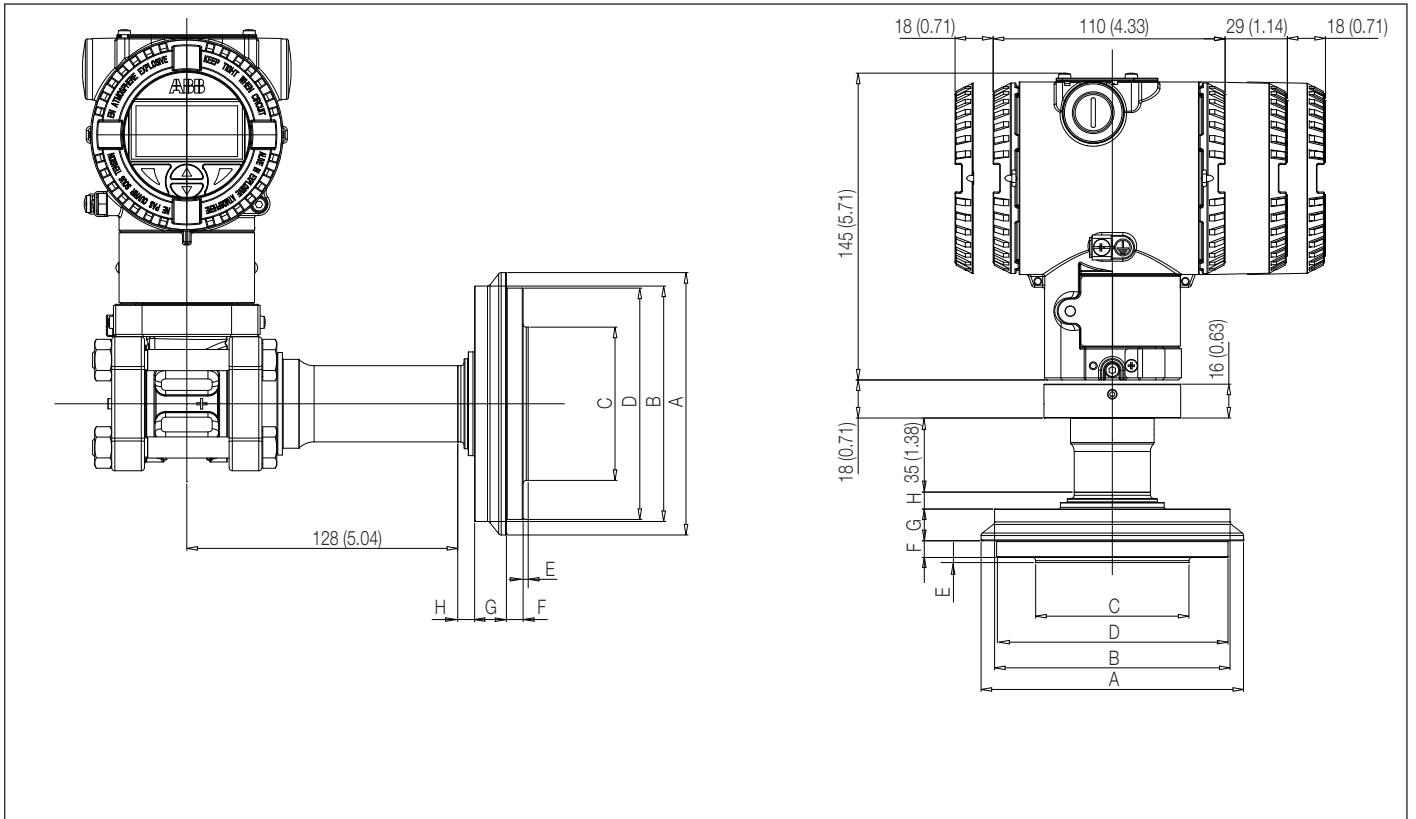

Size	Dimensions mm (in) for S26SS Cherry Burrell							
	A (dia)	B (dia)	C (dia)	D (dia)	E	F	G	H
2 in.	67 (2.64)	56 (2.2)	42 (1.65)	57 (2.24)	3.2 (0.13)	6.5 (0.26)	12.5 (0.49)	3 (0.12)
3 in.	98.4 (3.87)	81 (3.19)	72.42 (2.85)	83.8 (3.3)	2.4 (0.09)	7.9 (0.31)	15 (0.59)	3 (0.12)
4 in.	124 (4.88)	111.25 (4.38)	72.42 (2.85)	109.3 (4.3)	2.4 (0.09)	7.9 (0.31)	15 (0.59)	3 (0.12)

Model 266DDH Differential  
 Model 266HDH Gauge  
 Model 266NDH Absolute

266DDH with barrel housing and direct mount seal S26SS Sanitary flush

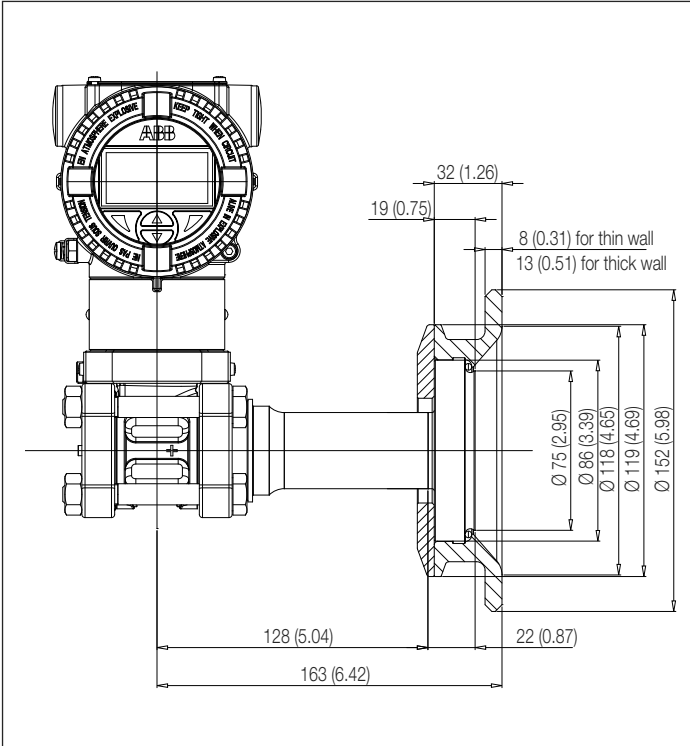

266HDH / 266NDH with barrel housing and direct mount seal S26SS Sanitary flush

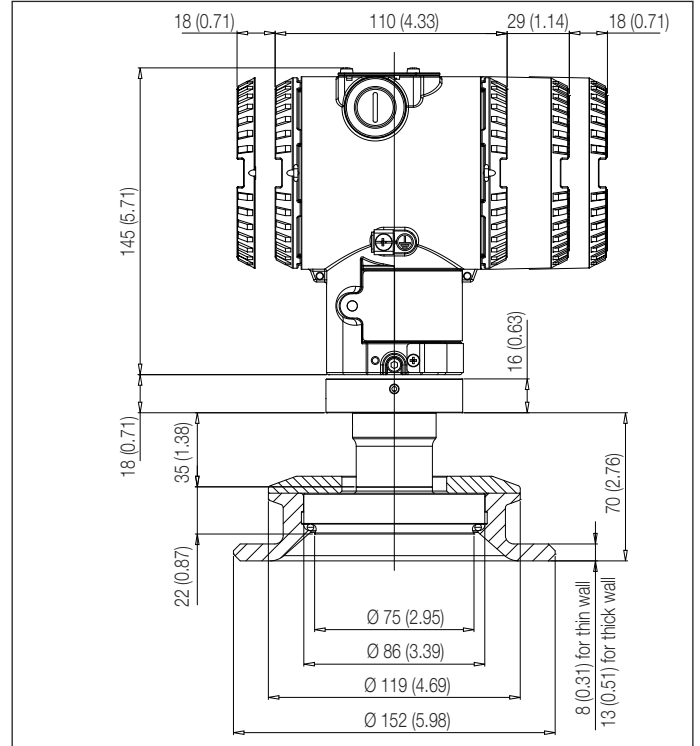

266HDH / 266NDH with barrel housing and direct mount seal S26SS beverage bolted

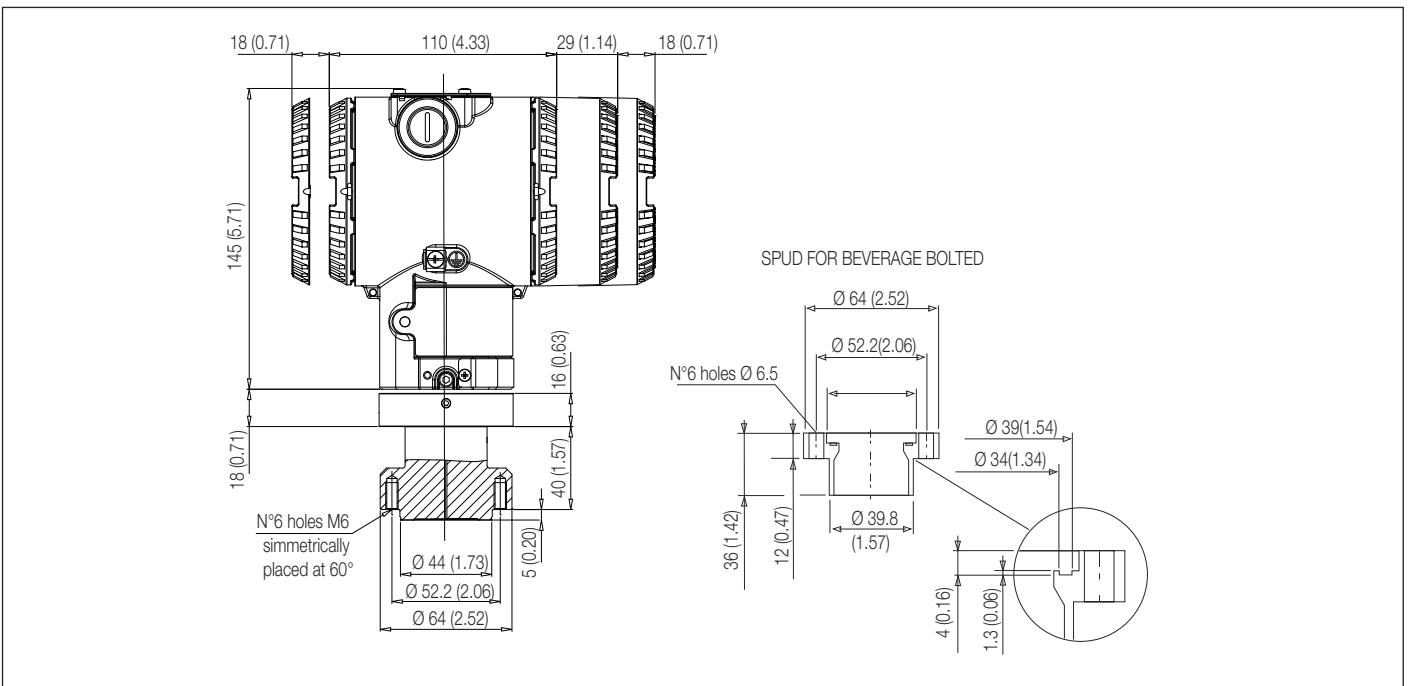

266DDH with barrel housing and direct mount seal S26SS Sanitary extended

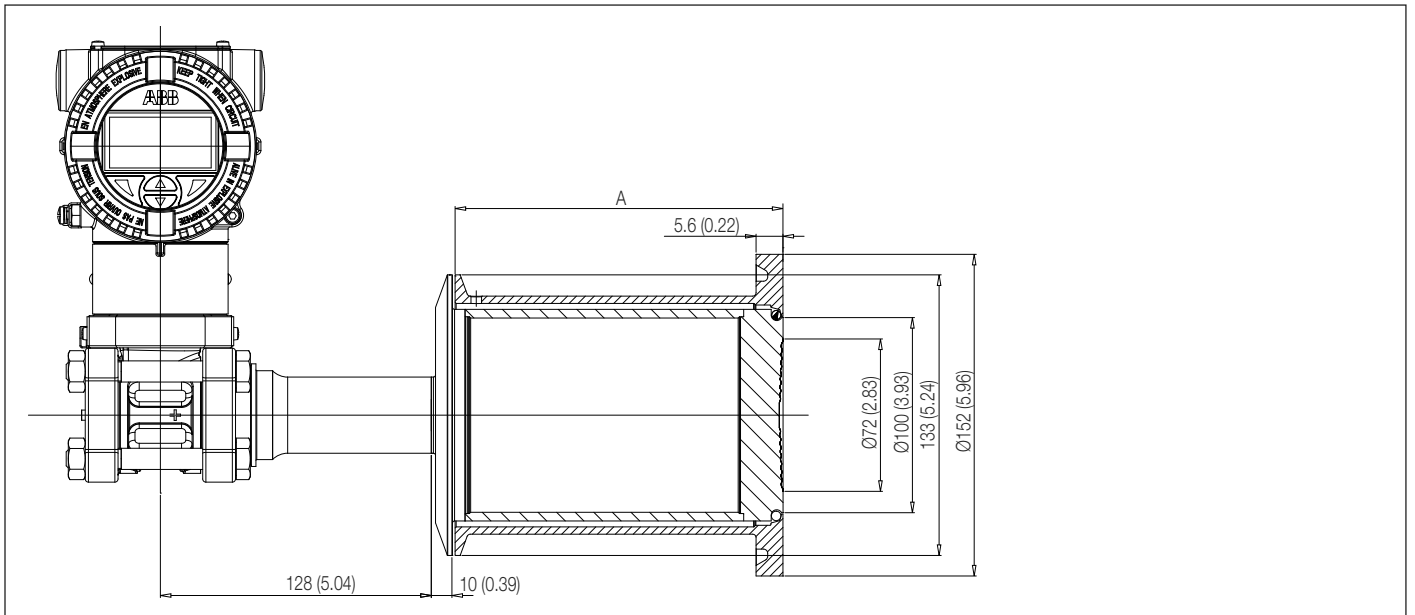

266HDH / 266NDH with barrel housing and direct mount seal S26SS Sanitary extended

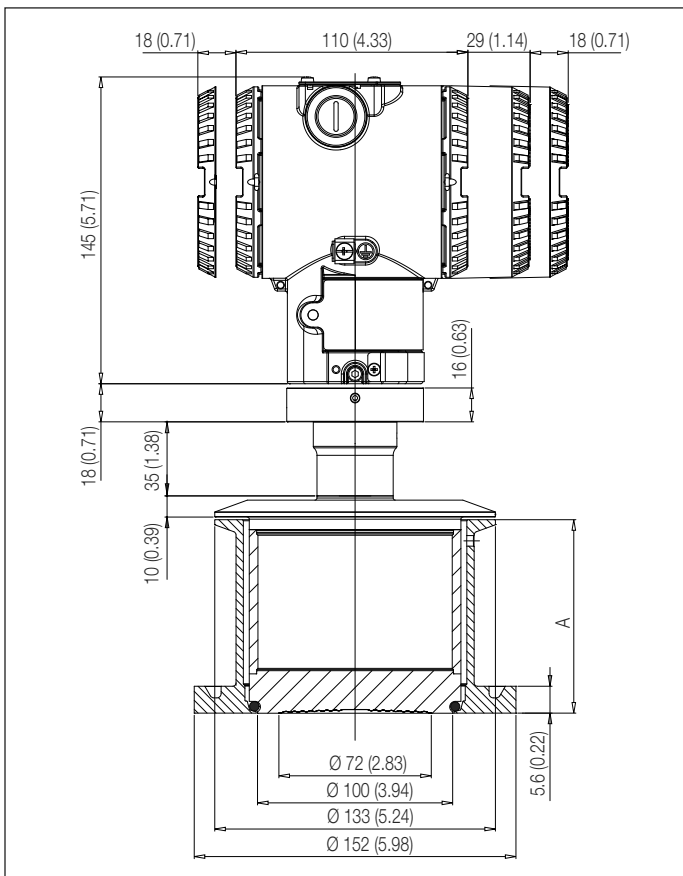

Size	Dimensions mm (in) for S26SS Sanitary extended	
	A	
2in	53.3 (2.1)	
4in	104.1 (4.1)	
6in	154.9 (6.1)	

Model 266DDH Differential  
 Model 266HDH Gauge  
 Model 266NDH Absolute

266HDH / 266NDH with barrel housing and direct mount seal S26KN pulp and paper NPT threaded connections

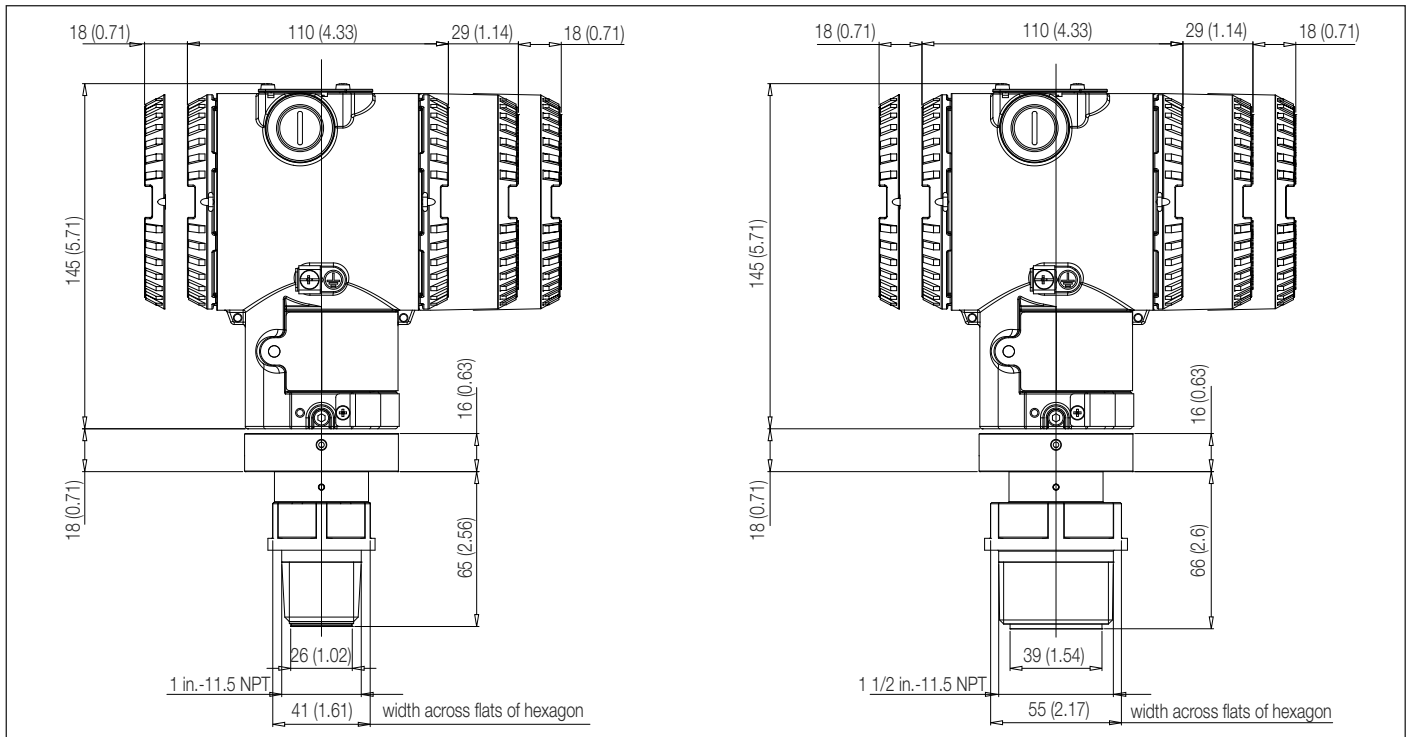

266HDH / 266NDH with barrel housing and direct mount seal S26KN pulp and paper Gas threaded connections

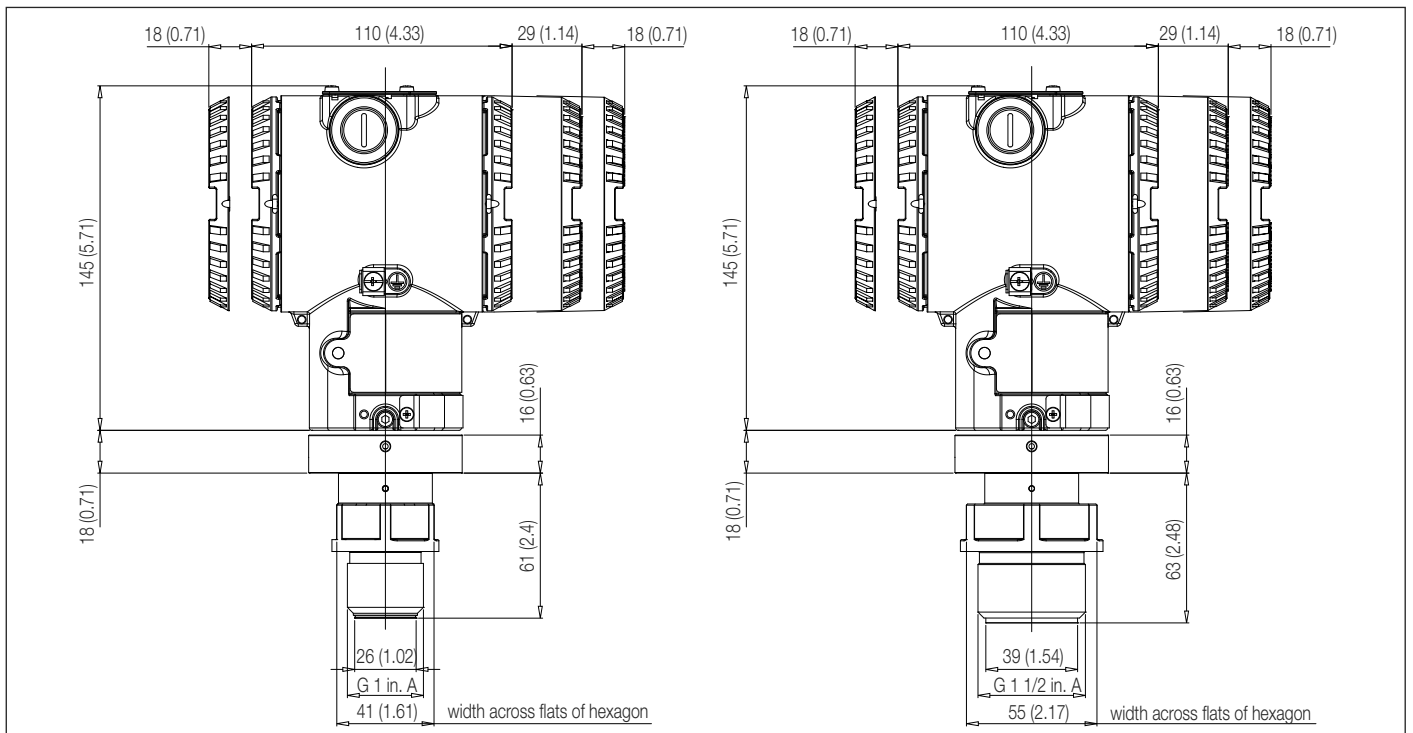

266HDH / 266NDH with barrel housing and direct mount seal S26KN pulp and paper sealing with gasket

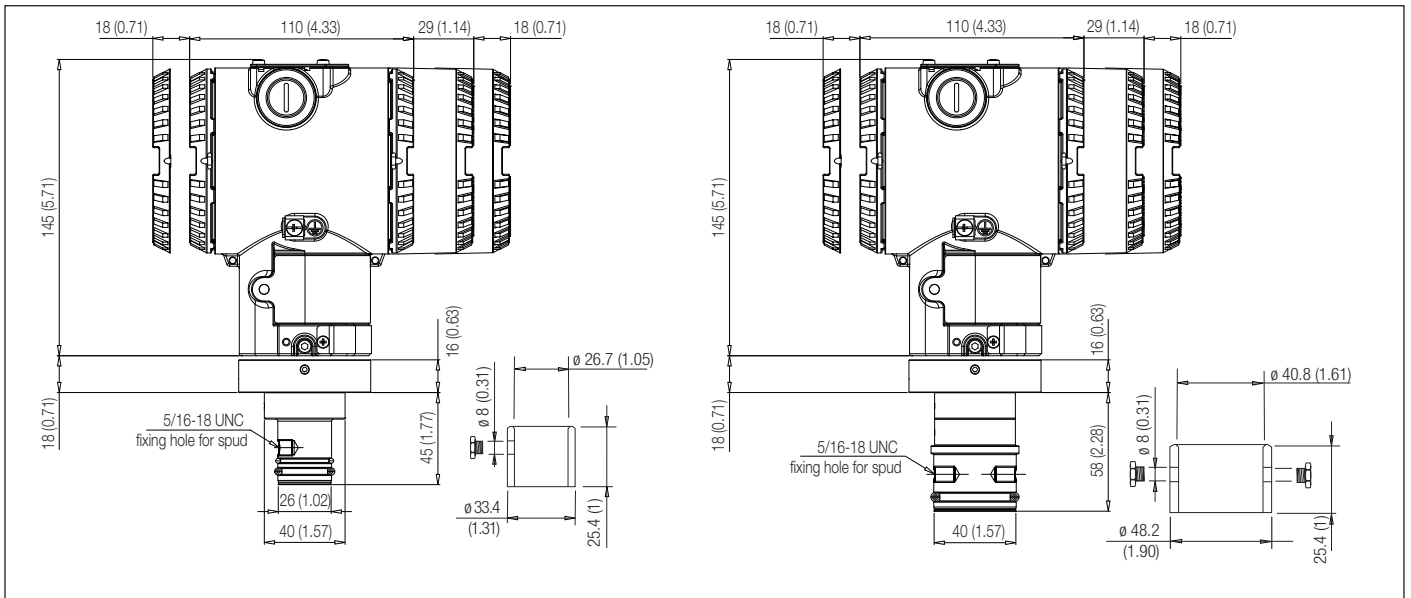

266HDH / 266NDH with barrel housing and direct mount seal S26KN pulp and paper ball valve connection

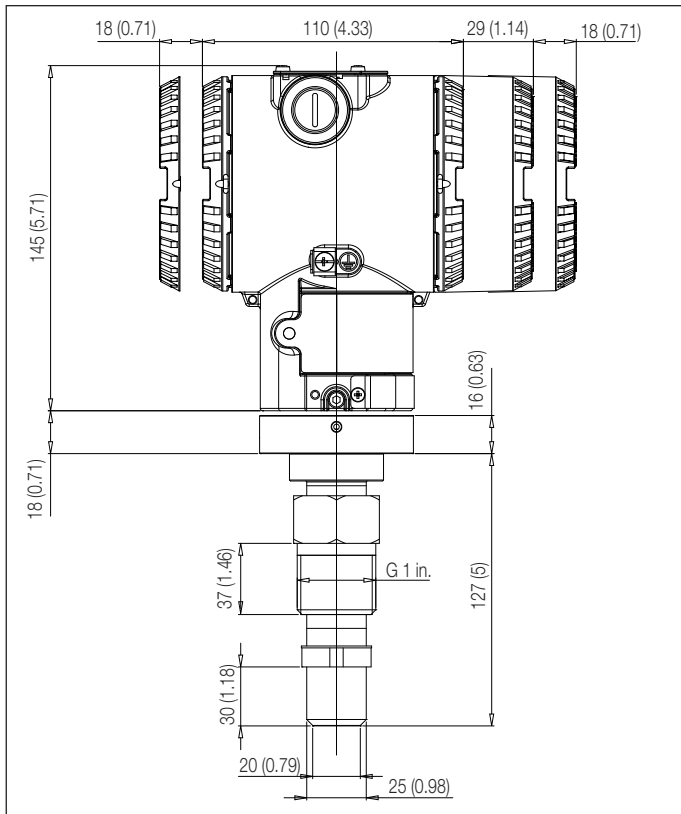

266HDH / 266NDH with barrel housing and direct mount seal S26KN pulp and paper to threaded spud

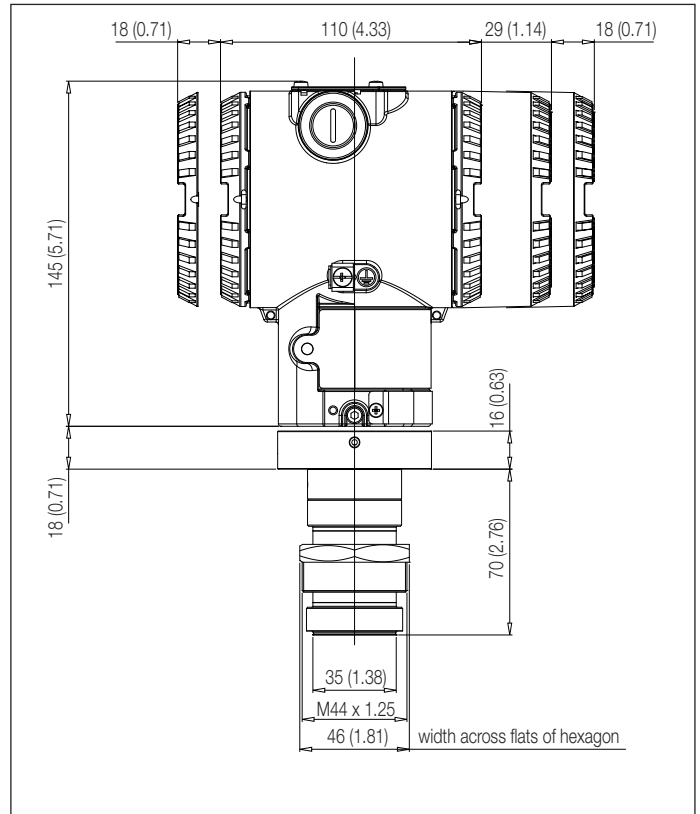

Model 266DDH Differential  
 Model 266HDH Gauge  
 Model 266NDH Absolute

266HDH / 266NDH with barrel housing and direct mount seal S26VN saddle and socket

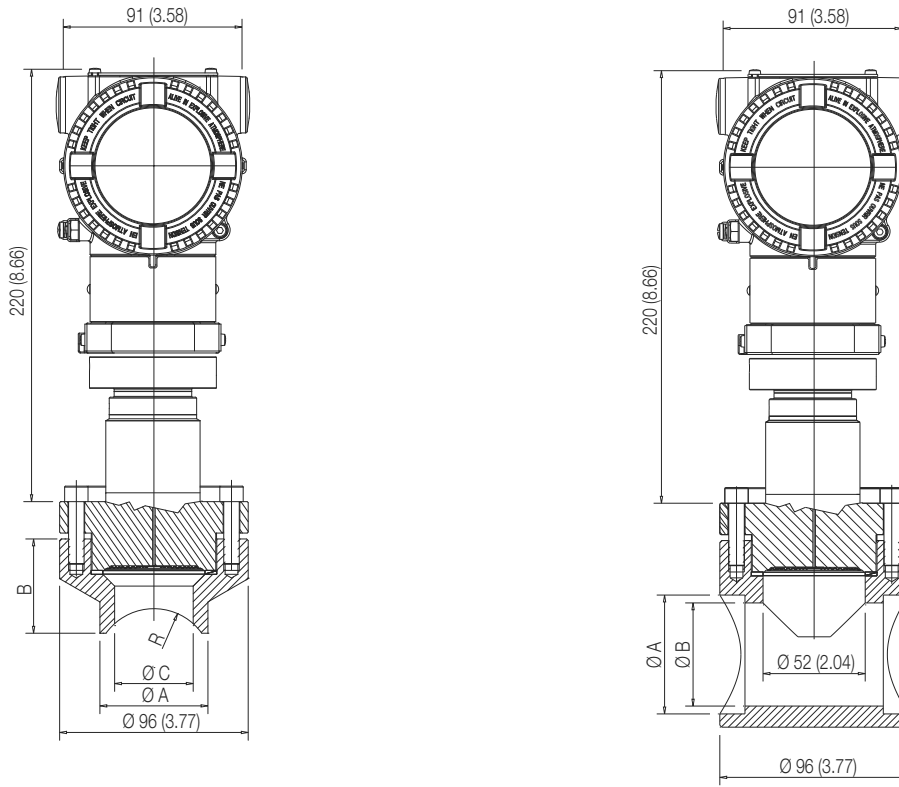

Fitting connection/ Size	Dimensions mm (in) for S26VN- saddle type			
	A (dia)	B	C (dia)	R
Saddle 2 in.	55 (2.17)	48 (1.89)	40 (1.57)	30
Saddle 2 1/2 in.	76 (3.0)	45 (1.77)	52 (2.05)	45
Saddle 3 in.	76 (3.0)	45 (1.77)	50 (1.97)	45
Saddle 4 in.	76 (3.0)	41 (1.61)	50 (1.97)	57
Saddle 5 in.	76 (3.0)	40 (1.57)	50 (1.97)	70
Saddle 6 in.	76 (3.0)	36 (1.42)	50 (1.97)	85

Fitting connection/ Size	Dimensions mm (in) for S26VN- socket type		
	A (dia)	B	C
Socket 1/2 in.	21.8 (0.86)	15.9 (0.63)	86 (3.39)
Socket 3/4 in.	27 (1.06)	21.2 (0.83)	96 (3.78)
Socket 1 in.	33.6 (1.32)	26.8 (1.06)	101 (3.98)
Socket 1 1/2 in.	48.5 (1.91)	41 (1.61)	121 (4.76)
Socket 2 in.	60.5 (2.38)	52.5 (2.07)	121 (4.76)

## Electrical connections

### HART Version

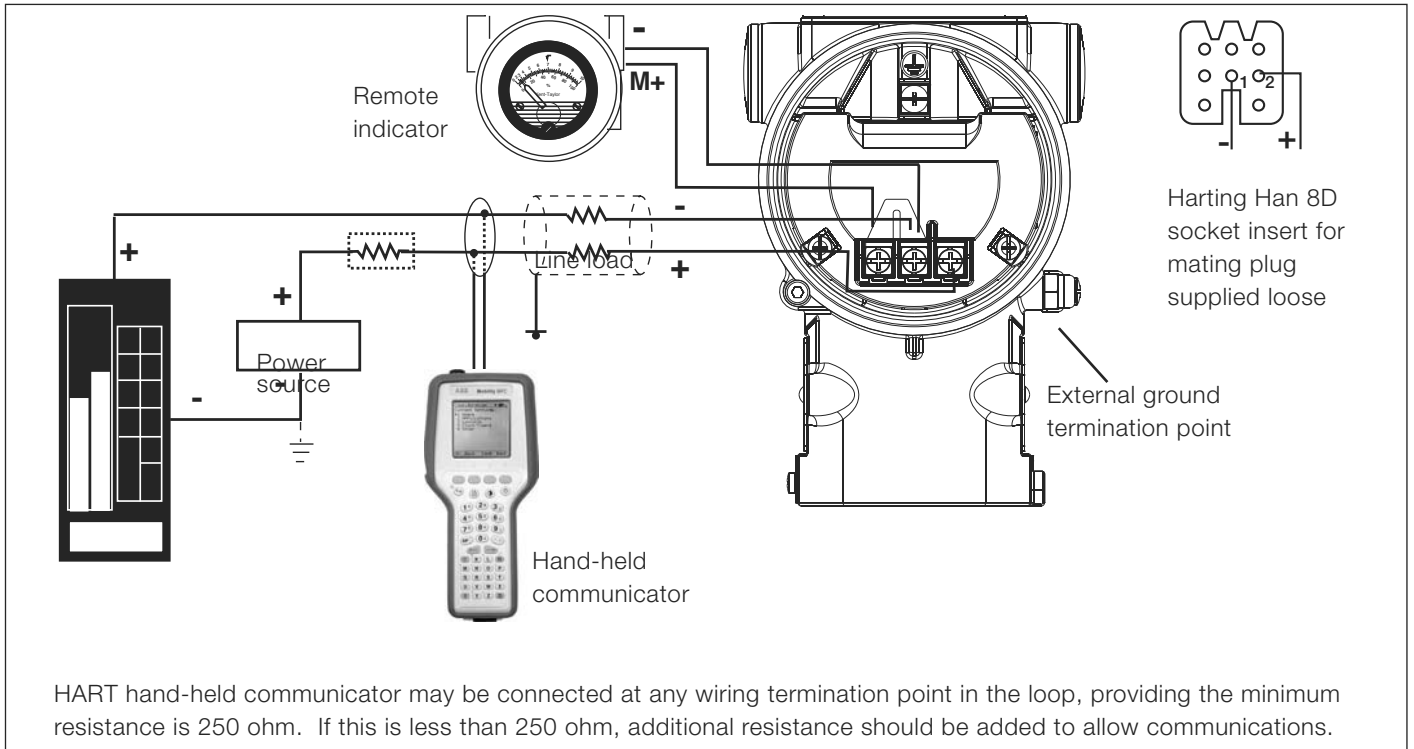

### FIELDBUS Versions

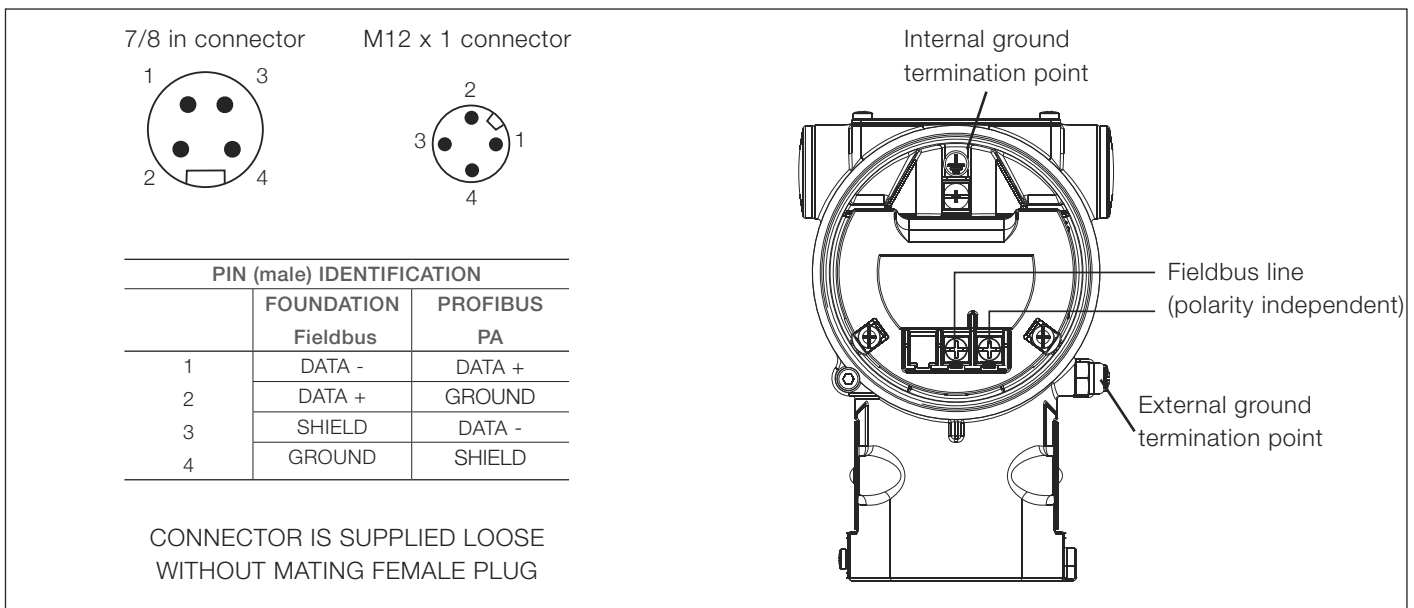

# Model 266DDH Differential

# Model 266HDH Gauge

# Model 266NDH Absolute

## Ordering information

### BASIC ORDERING INFORMATION model 266DDH Differential Pressure Transmitter with direct mount seal

Select one character or set of characters from each category and specify complete catalog number.

Refer to additional ordering information and specify one or more codes for each transmitter if additional options are required.

<b>BASE MODEL - 1<sup>st</sup> to 6<sup>th</sup> characters</b>				<b>2 6 6 D D H</b>	<b>X</b>	<b>S</b>	<b>X</b>	<b>X</b>	<b>X</b>	<b>X</b>	<b>X</b>
Differential Pressure Transmitter with direct mount seal – BASE ACCURACY 0.06 %											
<b>SENSOR - Span limits - 7<sup>th</sup> characters</b>											
0.8 and 16 kPa	8 and 160 mbar	3.2 and 64 inH2O		E							
0.67 and 40 kPa	6.7 and 400 mbar	2.67 and 160 inH2O		F							
1.1 and 65 kPa	11 and 650 mbar	4.35 and 260 inH2O		G							
2.67 and 160 kPa	26.7 and 1600 mbar	10.7 and 642 inH2O		H							
10 and 600 kPa	0.1 and 6 bar	1.45 and 87 psi		M							
40 and 2400 kPa	0.4 and 24 bar	5.8 and 348 psi		P							
134 and 8000 kPa	1.34 and 80 bar	19.4 and 1160 psi		Q							
267 and 16000 kPa	2.67 and 160 bar	38.7 and 2320 psi		S							
<b>Use code - 8<sup>th</sup> characters</b>						<b>S</b>					
<b>Diaphragm material / Fill fluid (wetted parts) - 9<sup>th</sup> characters</b>											
AISI 316 L ss	Silicone oil			NACE	S						
Hastelloy C-276™	Silicone oil			NACE	K						
Monel 400™	Silicone oil			NACE	M						
Tantalum	Silicone oil			NACE	T						
AISI 316 L ss	Inert fluid - Galden	(Note 1)		NACE	A						
Hastelloy C-276™	Inert fluid - Galden	(Note 1)		NACE	F						
Monel 400™	Inert fluid - Galden	(Note 1)		NACE	C						
Tantalum	Inert fluid - Galden	(Note 1)		NACE	D						
AISI 316 L ss	Inert fluid - Halocarbon	(Note 1)		NACE	L						
Hastelloy C-276™	Inert fluid - Halocarbon	(Note 1)		NACE	P						
Monel 400™	Inert fluid - Halocarbon	(Note 1)		NACE	4						
Tantalum	Inert fluid - Halocarbon	(Note 1)		NACE	5						
AISI 316 L ss	Silicone oil			NACE	R						
AISI 316 L ss	Inert fluid - Galden	(Note 1)		NACE	2						
AISI 316 L ss	Inert fluid - Halocarbon	(Note 1)		NACE	W						

continued  
see next page

BASIC ORDERING INFORMATION model 266DDH Differential Pressure Transmitter				2	6	D	D	H	X	S	X	X	X
<b>Process flanges/adapters material and connection (wetted parts) - 10<sup>th</sup> characters</b>													
AISI 316 L ss for two seals construction		(Note 2)	NACE						R				
AISI 316 L ss (Horizontal connection)	1/4 – 18 NPT-f direct	(Note 3)	NACE						A				
AISI 316 L ss (Horizontal connection)	1/2 – 14 NPT-f through adapter	(Note 3)	NACE						B				
Hastelloy C-276™ (Horizontal connection)	1/4 – 18 NPT-f direct	(Notes 3, 4)	NACE						D				
Hastelloy C-276™ (Horizontal connection)	1/2 – 14 NPT-f through adapter	(Notes 3, 4)	NACE						E				
Monel 400™ (Horizontal connection)	1/4 – 18 NPT-f direct	(Notes 3, 4)	NACE						G				
Monel 400™ (Horizontal connection)	1/2 – 14 NPT-f through adapter	(Notes 3, 4)	NACE						H				
<b>Bolts/Gasket (wetted parts) - 11<sup>th</sup> characters</b>													
AISI 316 ss (NACE) without gaskets for two seals construction– (MWP = 16 MPa)		(Note 2)	NACE						R				
AISI 316 ss without gaskets for two seals construction		(Note 2)							S				
AISI 316 ss	Viton™	(Note 3)							1				
AISI 316 ss	PTFE	(Notes 1, 3)							2				
AISI 316 ss (NACE) – (MWP = 16 MPa)	Viton™	(Note 3)	NACE						3				
AISI 316 ss (NACE) – (MWP = 16 MPa)	PTFE	(Notes 1, 3)	NACE						4				
<b>Housing material and electrical connection - 12<sup>th</sup> characters</b>													
Aluminium alloy ( barrel version)	1/2 – 14 NPT												A
Aluminium alloy ( barrel version)	M20 x 1.5 (CM 20)												B
Aluminium alloy ( barrel version)	Harting Han 8D connector	(general purpose only)						(Note 5)					E
Aluminium alloy ( barrel version)	Fieldbus connector	(general purpose only)						(Note 5)					G
AISI 316 L ss ( barrel version)	1/2 – 14 NPT												S
AISI 316 L ss ( barrel version)	M20 x 1.5 (CM20)												T
AISI 316 L ss ( barrel version)	Fieldbus connector	(general purpose only)						(Note 5)					Z
Aluminium alloy (DIN version)	M20 x 1.5 (CM20)												J
Aluminium alloy (DIN version)	Harting Han 8D connector	(general purpose only)						(Note 5)					K
Aluminium alloy (DIN version)	Fieldbus connector	(general purpose only)						(Note 5)					W
<b>Output/Additional options - 13<sup>th</sup> characters</b>													
HART digital communication and 4 to 20 mA		No additional options						(Notes 6, 7)					H
HART digital communication and 4 to 20 mA		Options requested by “Additional ordering code”						(Note 6)					1
PROFIBUS PA		No additional options						(Notes 6, 7)					P
PROFIBUS PA		Options requested by “Additional ordering code”						(Note 7)					2
FOUNDATION Fieldbus		No additional options						(Notes 6, 7)					F
FOUNDATION Fieldbus		Options requested by “Additional ordering code”						(Note 7)					3
HART and 4 to 20 mA Safety - certified to IEC 61508		No additional options						(Notes 6, 7)					T
HART and 4 to 20 mA Safety - certified to IEC 61508		Options requested by “Additional ordering code”						(Note 6)					8

# Model 266DDH Differential

## Model 266HDH Gauge

## Model 266NDH Absolute

### ADDITIONAL ORDERING INFORMATION for model 266DDH

Add one or more 2-digit code(s) after the basic ordering information to select all required options

	XX	XX	XX	XX
<b>Drain/vent valve (material and position) (wetted parts)</b>				
AISI 316 L ss on process axis (Note 8) NACE	V1			
AISI 316 L ss on flange side top (Note 8) NACE	V2			
AISI 316 L ss on flange side bottom (Note 8) NACE	V3			
Hastelloy C-276™ on process axis (Note 9) NACE	V4			
Hastelloy C-276™ on flange side top (Note 9) NACE	V5			
Hastelloy C-276™ on flange side bottom (Note 9) NACE	V6			
Monel 400™ on process axis (Note 10) NACE	V7			
Monel 400™ on flange side top (Note 10) NACE	V8			
Monel 400™ on flange side bottom (Note 10) NACE	V9			
<b>Hazardous area certifications</b>				
ATEX Intrinsic Safety II 1 G and II 1/2 G Ex ia IIC T6; II 1 D Ex iaD 20 T 95 °C and II 1/2D Ex iaD 21 T95 °C				E1
ATEX Explosion Proof Group II Category 1/2 G Ex d IIC T6 and Group II Category 1/2 D Ex tD A21 IP67 T85 °C (Note 11)				E2
ATEX Type „N“ Group II Category 3 G Ex nL IIC T6 and Group II Category 3 D Ex tD A22 IP67 T85 °C				E3
Combined ATEX - Intrinsic Safety, Explosion Proof and Type „N“ (Note 11)				EW
Combined ATEX, FM Approvals (USA) and FM Approvals (Canada) (Note 11)				EN
FM Approvals (Canada) approval (Note 11)				E4
FM Approvals (USA) approval (Note 11)				E6
FM Approvals (USA and Canada) Intrinsic Safety				EA
FM Approvals (USA and Canada) Explosion Proof (Note 11)				EB
FM Approvals (USA and Canada) Nonincendive				EC
IEC Intrinsic Safety II 1 G and II 1/2 G Ex ia IIC T6; II 1 D Ex iaD 20 T 95 °C and II 1/2D Ex iaD 21 T95 °C;				E8
IEC Explosion Proof Group II Category 1/2 G Ex d IIC T6 and Group II Category 1/2 D Ex tD A21 IP67 T85 °C (Note 11)				E9
IEC Group II Category 3 G Ex nL IIC T6 and Group II Category 3 D Ex tD A22 IP67 T85 °C				ER
<b>Other hazardous area certifications</b>				
GOST (Russia) EEx ia				W1
GOST (Russia) EEx d (Note 11)				W2
GOST (Kazakhstan) EEx ia				W3
GOST (Kazakhstan) EEx d (Note 11)				W4
Inmetro (Brazil) EEx ia				W5
Inmetro (Brazil) EEx d (Note 11)				W6
Inmetro (Brazil) EEx nL				W7
<b>Integral LCD</b>				
Digital LCD integral display				L1
TTG (Through-The-Glass) digital LCD controlled display				L5
<b>Surge</b>				
Surge/Transient Protector				S2

ADDITIONAL ORDERING INFORMATION for model 266DDH	XX	XX	XX	XX	XX
<b>Operating manual (up to 2 different selections allowed)</b>					
German	M1				
Italian	M2				
Spanish	M3				
French	M4				
English	M5				
Chinese	M6				
<b>Plates language</b>					
German		T1			
Italian		T2			
Spanish		T3			
French		T4			
<b>Additional tag plate</b>					
Supplemental wired-on stainless steel plate				I1	
Laser printing of tag on stainless steel plate				I2	
<b>Configuration</b>					
Standard – Pressure = inH2O/ psi at 68 °F; Temperature = deg. F					N2
Standard – Pressure = inH2O/ psi at 39.2 °F; Temperature = deg. F					N3
Standard – Pressure = inH2O/ psi at 20 °C; Temperature = deg. C					N4
Standard – Pressure = inH2O/ psi at 4 °C; Temperature = deg. C					N5
Custom					N6
<b>Certificates (up to 2 different selections allowed)</b>					
Inspection certificate EN 10204–3.1 of calibration (9-point)					C1
Inspection certificate EN 10204–3.1 of the cleanliness stage					C3
Inspection certificate EN 10204–3.1 of helium leakage test of the sensor module					C4
Inspection certificate EN 10204–3.1 of the pressure test					C5
Certificate of compliance with the order EN 10204–2.1 of instrument design					C6
Overfill protection					C9
Printed record of configured data of transmitter					CG
PMI test of wetted parts					CT

# Model 266DDH Differential

## Model 266HDH Gauge

## Model 266NDH Absolute

ADDITIONAL ORDERING INFORMATION FOR MODEL 266DDH	XX	XX	XX	XX
<b>Approvals</b>				
GOST (Russia) without Ex	Y1			
GOST (Kazakhstan) without Ex	Y2			
GOST (Ukraine) without Ex	Y3			
GOST (Belarus) without Ex	Y4			
DNV approval		YA		
Lloyd approval		YB		
Approval for Custody transfer		YC		
Bureau Veritas approval		YD		
<b>Material traceability</b>				
Certificate of compliance with the order EN 10204–2.1 of process wetted parts				H1
Inspection certificate EN 10204–3.1 of process wetted parts				H3
Test report EN 10204–2.2 of pressure bearing and process wetted parts				H4
<b>Connector</b>				
Fieldbus 7/8 in. (Recommended for FOUNDATION Fieldbus) - (supplied loose without mating female plug)	(Notes 7, 12)			U1
Fieldbus M12x1 (Recommended for PROFIBUS PA) - (supplied loose without mating female plug)	(Notes 7, 12)			U2
Harting Han 8D – straight entry - (supplied loose)	(Notes 6, 12)			U3
Harting Han 8D – angle entry - (supplied loose)	(Notes 6, 12)			U4

Note 1: Suitable for oxygen service

Note 2: Not available with low side diaphragm code S, K, M, T, A, F, C, D, L, P, 4, 5

Note 3: Not available with low side diaphragm code R, 2, W

Note 4: Not available with diaphragm material/fill fluid code S, A, L

Note 5: Select type in additional ordering code

Note 6: Not available with Housing code G, Z, W

Note 7: Not available with Housing code E, K

Note 8: Not available with Process flanges/adapters code D, E, G, H, R

Note 9: Not available with Process flanges/adapters code A, B, G, H, R

Note 10: Not available with Process flanges/adapters code A, B, D, E, R

Note 11: Not available with Housing code J, K, W

Note 12: Not available with Housing code A, B, S, T, J

### Standard delivery items (can be differently specified by additional ordering code)

- Adapter supplied loose
- Plug on axis (no drain/vent valve)
- General purpose (no electrical certification)
- No display, no surge protection
- English manual and labels
- Configuration with kPa and deg. C units
- No test, inspection or material traceability certificates

THE SELECTION OF SUITABLE WETTED PARTS AND FILLING FLUID FOR COMPATIBILITY WITH THE PROCESS MEDIA IS A CUSTOMER'S RESPONSIBILITY, IF NOT OTHERWISE NOTIFIED BEFORE MANUFACTURING.

NACE CONFORMITY IS ACCORDING TO RECOMMENDATIONS PER MR0175. AISI 316 AND HASTELLOY C-276 ALSO COMPLY WITH MR0103 IF ALREADY WITH MR0175.

## BASIC ORDERING INFORMATION model 266HDH Gauge Pressure Transmitter with direct mount seal

Select one character or set of characters from each category and specify complete catalog number.

Refer to additional ordering information and specify one or more codes for each transmitter if additional options are required.

BASE MODEL - 1 <sup>st</sup> to 6 <sup>th</sup> characters			2	6	H	D	H	X	X	X	X	X
Gauge Pressure Transmitter with direct mount seal – BASE ACCURACY 0.06 %												
SENSOR - Span limits - 7 <sup>th</sup> characters												
1.1 and 65 kPa	11 and 650 mbar	4.35 and 260 inH2O						G				
2.67 and 160 kPa	26.7 and 1600 mbar	10.7 and 642 inH2O						H				
10 and 600 kPa	0.1 and 6 bar	1.45 and 87 psi						M				
40 and 2400 kPa	0.4 and 24 bar	5.8 and 348 psi						P				
134 and 8000 kPa	1.34 and 80 bar	19.4 and 1160 psi						Q				
267 and 16000 kPa	2.67 and 160 bar	38.7 and 2320 psi						S				
Diaphragm material / Fill fluid - 8 <sup>th</sup> characters												
AISI 316 L ss		Silicone oil								R		
AISI 316 L ss		Inert fluid - Galden			(Note 1)					2		
AISI 316 L ss		Inert fluid - Halocarbon			(Note 1)					W		
Process connection (wetted parts) - 9 <sup>th</sup> characters												
Direct mount seal	(one seal to be quoted separately)										M	
Housing material and electrical connection - 10 <sup>th</sup> characters												
Aluminium alloy ( barrel version)		1/2 – 14 NPT										A
Aluminium alloy ( barrel version)		M20 x 1.5 (CM 20)										B
Aluminium alloy ( barrel version)		Harting Han 8D connector			(general purpose only)				(Note 2)			E
Aluminium alloy ( barrel version)		Fieldbus connector			(general purpose only)				(Note 2)			G
AISI 316 L ss ( barrel version)		1/2 – 14 NPT										S
AISI 316 L ss ( barrel version)		M20 x 1.5 (CM20)										T
AISI 316 L ss ( barrel version)		Fieldbus connector			(general purpose only)				(Note 2)			Z
Aluminium alloy (DIN version)		M20 x 1.5 (CM20)										J
Aluminium alloy (DIN version)		Harting Han 8D connector			(general purpose only)				(Note 2)			K
Aluminium alloy (DIN version)		Fieldbus connector			(general purpose only)				(Note 2)			W
Output/Additional options - 11 <sup>th</sup> characters												
HART digital communication and 4 to 20 mA		No additional options								(Notes 3, 4)		H
HART digital communication and 4 to 20 mA		Options requested by “Additional ordering code”								(Note 3)		1
PROFIBUS PA		No additional options								(Notes 3, 4)		P
PROFIBUS PA		Options requested by “Additional ordering code”								(Note 4)		2
FOUNDATION Fieldbus		No additional options								(Notes 3, 4)		F
FOUNDATION Fieldbus		Options requested by “Additional ordering code”								(Note 4)		3
HART and 4 to 20 mA Safety - certified to IEC 61508		No additional options								(Notes 3, 4)		T
HART and 4 to 20 mA Safety - certified to IEC 61508		Options requested by “Additional ordering code”								(Note 3)		8

# Model 266DDH Differential

## Model 266HDH Gauge

## Model 266NDH Absolute

### ADDITIONAL ORDERING INFORMATION for model 266HDH

Add one or more 2-digit code(s) after the basic ordering information to select all required options

	XX	XX	XX
<b>Hazardous area certifications</b>			
ATEX Intrinsic Safety II 1 G and II 1/2 G Ex ia IIC T6; II 1 D Ex iaD 20 T 95 °C and II 1/2D Ex iaD 21 T95 °C	E1		
ATEX Explosion Proof Group II Category 1/2 G Ex d IIC T6 and Group II Category 1/2 D Ex tD A21 IP67 T85 °C (Note 5)	E2		
ATEX Type „N“ Group II Category 3 G Ex nL IIC T6 and Group II Category 3 D Ex tD A22 IP67 T85 °C	E3		
Combined ATEX - Intrinsic Safety, Explosion Proof and Type „N“ (Note 5)	EW		
Combined ATEX, FM Approvals (USA) and FM Approvals (Canada) (Note 5)	EN		
FM Approvals (Canada) approval (Note 5)	E4		
FM Approvals (USA) approval (Note 5)	E6		
FM Approvals (USA and Canada) Intrinsic Safety	EA		
FM Approvals (USA and Canada) Explosion Proof (Note 5)	EB		
FM Approvals (USA and Canada) Nonincendive	EC		
IEC Intrinsic Safety II 1 G and II 1/2 G Ex ia IIC T6; II 1 D Ex iaD 20 T 95 °C and II 1/2D Ex iaD 21 T95 °C;	E8		
IEC Explosion Proof Group II Category 1/2 G Ex d IIC T6 and Group II Category 1/2 D Ex tD A21 IP67 T85 °C (Note 5)	E9		
IEC Group II Category 3 G Ex nL IIC T6 and Group II Category 3 D Ex tD A22 IP67 T85 °C	ER		
<b>Other hazardous area certifications</b>			
GOST (Russia) EEx ia	W1		
GOST (Russia) EEx d (Note 5)	W2		
GOST (Kazakhstan) EEx ia	W3		
GOST (Kazakhstan) EEx d (Note 5)	W4		
Inmetro (Brazil) EEx ia	W5		
Inmetro (Brazil) EEx d (Note 5)	W6		
Inmetro (Brazil) EEx nL	W7		
<b>Integral LCD</b>			
Digital LCD integral display		L1	
TTG (Through-The-Glass) digital LCD controlled display		L5	
<b>Surge</b>			
Surge/Transient Protector			S2

ADDITIONAL ORDERING INFORMATION for model 266HDH	XX	XX	XX	XX	XX
<b>Operating manual (up to 2 different selections allowed)</b>					
German	M1				
Italian	M2				
Spanish	M3				
French	M4				
English	M5				
Chinese	M6				
<b>Plates language</b>					
German		T1			
Italian		T2			
Spanish		T3			
French		T4			
<b>Additional tag plate</b>					
Supplemental wired-on stainless steel plate				I1	
Laser printing of tag on stainless steel plate				I2	
<b>Configuration</b>					
Standard – Pressure = inH2O/ psi at 68 °F; Temperature = deg. F					N2
Standard – Pressure = inH2O/ psi at 39.2 °F; Temperature = deg. F					N3
Standard – Pressure = inH2O/ psi at 20 °C; Temperature = deg. C					N4
Standard – Pressure = inH2O/ psi at 4 °C; Temperature = deg. C					N5
Custom					N6
<b>Certificates (up to 2 different selections allowed)</b>					
Inspection certificate EN 10204–3.1 of calibration (9-point)					C1
Inspection certificate EN 10204–3.1 of the cleanliness stage					C3
Inspection certificate EN 10204–3.1 of helium leakage test of the sensor module					C4
Inspection certificate EN 10204–3.1 of the pressure test					C5
Certificate of compliance with the order EN 10204–2.1 of instrument design					C6
Overfill protection					C9
Printed record of configured data of transmitter					CG
PMI test of wetted parts					CT

# Model 266DDH Differential

## Model 266HDH Gauge

## Model 266NDH Absolute

ADDITIONAL ORDERING INFORMATION FOR MODEL 266HDH	XX	XX	XX	XX
<b>Approvals</b>				
GOST (Russia) without Ex	Y1			
GOST (Kazakhstan) without Ex	Y2			
GOST (Ukraine) without Ex	Y3			
GOST (Belarus) without Ex	Y4			
DNV approval		YA		
Lloyd approval		YB		
Approval for Custody transfer		YC		
Bureau Veritas approval		YD		
<b>Material traceability</b>				
Certificate of compliance with the order EN 10204–2.1 of process wetted parts				H1
Inspection certificate EN 10204–3.1 of process wetted parts				H3
Test report EN 10204–2.2 of pressure bearing and process wetted parts				H4
<b>Connector</b>				
Fieldbus 7/8 in. (Recommended for FOUNDATION Fieldbus) - (supplied loose without mating female plug)	(Notes 4, 6)			U1
Fieldbus M12x1 (Recommended for PROFIBUS PA) - (supplied loose without mating female plug)	(Notes 4, 6)			U2
Harting Han 8D – straight entry - (supplied loose)	(Notes 3, 6)			U3
Harting Han 8D – angle entry - (supplied loose)	(Notes 3, 6)			U4

- Note 1: Suitable for oxygen service  
 Note 2: Select type in additional ordering code  
 Note 3: Not available with Housing code G, Z, W  
 Note 4: Not available with Housing code E, K  
 Note 5: Not available with Housing code J, K, W  
 Note 6: Not available with Housing code A, B, S, T, J

### Standard delivery items (can be differently specified by additional ordering code)

- General purpose (no electrical certification)
- No display, no surge protection
- English manual and labels
- Configuration with kPa and deg. C units
- No test, inspection or material traceability certificates

THE SELECTION OF SUITABLE WETTED PARTS AND FILLING FLUID FOR COMPATIBILITY WITH THE PROCESS MEDIA IS A CUSTOMER'S RESPONSIBILITY, IF NOT OTHERWISE NOTIFIED BEFORE MANUFACTURING.

NACE CONFORMITY IS ACCORDING TO RECOMMENDATIONS PER MR0175. AISI 316 AND HASTELLOY C-276 ALSO COMPLY WITH MR0103 IF ALREADY WITH MR0175.

## BASIC ORDERING INFORMATION model 266NDH Absolute Pressure Transmitter with direct mount seal

Select one character or set of characters from each category and specify complete catalog number.

Refer to additional ordering information and specify one or more codes for each transmitter if additional options are required.

BASE MODEL - 1 <sup>st</sup> to 6 <sup>th</sup> characters			2	6	N	D	H	X	X	X	X	X
Absolute Pressure Transmitter with direct mount seal – BASE ACCURACY 0.075 %												
<b>SENSOR - Span limits - 7<sup>th</sup> characters</b>												
1.1 and 65 kPa	11 and 650 mbar	4.35 and 260 inH <sub>2</sub> O						G				
2.67 and 160 kPa	26.7 and 1600 mbar	10.7 and 642 inH <sub>2</sub> O						H				
10 and 600 kPa	0.1 and 6 bar	1.45 and 87 psi						M				
40 and 2400 kPa	0.4 and 24 bar	5.8 and 348 psi						P				
134 and 8000 kPa	1.34 and 80 bar	19.4 and 1160 psi						Q				
267 and 16000 kPa	2.67 and 160 bar	38.7 and 2320 psi						S				
<b>Diaphragm material / Fill fluid - 8<sup>th</sup> characters</b>												
AISI 316 L ss		Silicone oil								R		
AISI 316 L ss		Inert fluid - Galden			(Note 1)					2		
AISI 316 L ss		Inert fluid - Halocarbon			(Note 1)					W		
<b>Process connection (wetted parts) - 9<sup>th</sup> characters</b>												
Direct mount seal	(one seal to be quoted separately)										M	
<b>Housing material and electrical connection - 10<sup>th</sup> characters</b>												
Aluminium alloy ( barrel version)		1/2 – 14 NPT										A
Aluminium alloy ( barrel version)		M20 x 1.5 (CM 20)										B
Aluminium alloy ( barrel version)		Harting Han 8D connector			(general purpose only)				(Note 2)			E
Aluminium alloy ( barrel version)		Fieldbus connector			(general purpose only)				(Note 2)			G
AISI 316 L ss ( barrel version)		1/2 – 14 NPT										S
AISI 316 L ss ( barrel version)		M20 x 1.5 (CM20)										T
AISI 316 L ss ( barrel version)		Fieldbus connector			(general purpose only)				(Note 2)			Z
Aluminium alloy (DIN version)		M20 x 1.5 (CM20)										J
Aluminium alloy (DIN version)		Harting Han 8D connector			(general purpose only)				(Note 2)			K
Aluminium alloy (DIN version)		Fieldbus connector			(general purpose only)				(Note 2)			W
<b>Output/Additional options - 11<sup>th</sup> characters</b>												
HART digital communication and 4 to 20 mA		No additional options								(Notes 3, 4)		H
HART digital communication and 4 to 20 mA		Options requested by “Additional ordering code”								(Note 3)		1
PROFIBUS PA		No additional options								(Notes 3, 4)		P
PROFIBUS PA		Options requested by “Additional ordering code”								(Note 4)		2
FOUNDATION Fieldbus		No additional options								(Notes 3, 4)		F
FOUNDATION Fieldbus		Options requested by “Additional ordering code”								(Note 4)		3
HART and 4 to 20 mA Safety - certified to IEC 61508		No additional options								(Notes 3, 4)		T
HART and 4 to 20 mA Safety - certified to IEC 61508		Options requested by “Additional ordering code”								(Note 3)		8

# Model 266DDH Differential

## Model 266HDH Gauge

## Model 266NDH Absolute

### ADDITIONAL ORDERING INFORMATION for model 266NDH

Add one or more 2-digit code(s) after the basic ordering information to select all required options

	XX	XX	XX
<b>Hazardous area certifications</b>			
ATEX Intrinsic Safety II 1 G and II 1/2 G Ex ia IIC T6; II 1 D Ex iaD 20 T 95 °C and II 1/2D Ex iaD 21 T95 °C	E1		
ATEX Explosion Proof Group II Category 1/2 G Ex d IIC T6 and Group II Category 1/2 D Ex tD A21 IP67 T85 °C (Note 5)	E2		
ATEX Type „N“ Group II Category 3 G Ex nL IIC T6 and Group II Category 3 D Ex tD A22 IP67 T85 °C	E3		
Combined ATEX - Intrinsic Safety, Explosion Proof and Type „N“ (Note 5)	EW		
Combined ATEX, FM Approvals (USA) and FM Approvals (Canada) (Note 5)	EN		
FM Approvals (Canada) approval (Note 5)	E4		
FM Approvals (USA) approval (Note 5)	E6		
FM Approvals (USA and Canada) Intrinsic Safety	EA		
FM Approvals (USA and Canada) Explosion Proof (Note 5)	EB		
FM Approvals (USA and Canada) Nonincendive	EC		
IEC Intrinsic Safety II 1 G and II 1/2 G Ex ia IIC T6; II 1 D Ex iaD 20 T 95 °C and II 1/2D Ex iaD 21 T95 °C;	E8		
IEC Explosion Proof Group II Category 1/2 G Ex d IIC T6 and Group II Category 1/2 D Ex tD A21 IP67 T85 °C (Note 5)	E9		
IEC Group II Category 3 G Ex nL IIC T6 and Group II Category 3 D Ex tD A22 IP67 T85 °C	ER		
<b>Other hazardous area certifications</b>			
GOST (Russia) EEx ia	W1		
GOST (Russia) EEx d (Note 5)	W2		
GOST (Kazakhstan) EEx ia	W3		
GOST (Kazakhstan) EEx d (Note 5)	W4		
Inmetro (Brazil) EEx ia	W5		
Inmetro (Brazil) EEx d (Note 5)	W6		
Inmetro (Brazil) EEx nL	W7		
<b>Integral LCD</b>			
Digital LCD integral display		L1	
TTG (Through-The-Glass) digital LCD controlled display		L5	
<b>Surge</b>			
Surge/Transient Protector			S2

ADDITIONAL ORDERING INFORMATION for model 266NDH	XX	XX	XX	XX	XX
<b>Operating manual (up to 2 different selections allowed)</b>					
German	M1				
Italian	M2				
Spanish	M3				
French	M4				
English	M5				
Chinese	M6				
<b>Plates language</b>					
German		T1			
Italian		T2			
Spanish		T3			
French		T4			
<b>Additional tag plate</b>					
Supplemental wired-on stainless steel plate				I1	
Laser printing of tag on stainless steel plate				I2	
<b>Configuration</b>					
Standard – Pressure = inH2O/ psi at 68 °F; Temperature = deg. F					N2
Standard – Pressure = inH2O/ psi at 39.2 °F; Temperature = deg. F					N3
Standard – Pressure = inH2O/ psi at 20 °C; Temperature = deg. C					N4
Standard – Pressure = inH2O/ psi at 4 °C; Temperature = deg. C					N5
Custom					N6
<b>Certificates (up to 2 different selections allowed)</b>					
Inspection certificate EN 10204–3.1 of calibration (9-point)					C1
Inspection certificate EN 10204–3.1 of the cleanliness stage					C3
Inspection certificate EN 10204–3.1 of helium leakage test of the sensor module					C4
Inspection certificate EN 10204–3.1 of the pressure test					C5
Certificate of compliance with the order EN 10204–2.1 of instrument design					C6
Overfill protection					C9
Printed record of configured data of transmitter					CG
PMI test of wetted parts					CT

# Model 266DDH Differential

## Model 266HDH Gauge

## Model 266NDH Absolute

ADDITIONAL ORDERING INFORMATION FOR MODEL 266NDH	XX	XX	XX	XX
<b>Approvals</b>				
GOST (Russia) without Ex	Y1			
GOST (Kazakhstan) without Ex	Y2			
GOST (Ukraine) without Ex	Y3			
GOST (Belarus) without Ex	Y4			
DNV approval		YA		
Lloyd approval		YB		
Approval for Custody transfer		YC		
Bureau Veritas approval		YD		
<b>Material traceability</b>				
Certificate of compliance with the order EN 10204–2.1 of process wetted parts				H1
Inspection certificate EN 10204–3.1 of process wetted parts				H3
Test report EN 10204–2.2 of pressure bearing and process wetted parts				H4
<b>Connector</b>				
Fieldbus 7/8 in. (Recommended for FOUNDATION Fieldbus) - (supplied loose without mating female plug)	(Notes 4, 6)			U1
Fieldbus M12x1 (Recommended for PROFIBUS PA) - (supplied loose without mating female plug)	(Notes 4, 6)			U2
Harting Han 8D – straight entry - (supplied loose)	(Notes 3, 6)			U3
Harting Han 8D – angle entry - (supplied loose)	(Notes 3, 6)			U4

- Note 1: Suitable for oxygen service  
 Note 2: Select type in additional ordering code  
 Note 3: Not available with Housing code G, Z, W  
 Note 4: Not available with Housing code E, K  
 Note 5: Not available with Housing code J, K, W  
 Note 6: Not available with Housing code A, B, S, T, J

### Standard delivery items (can be differently specified by additional ordering code)

- General purpose (no electrical certification)
- No display, no surge protection
- English manual and labels
- Configuration with kPa and deg. C units
- No test, inspection or material traceability certificates

THE SELECTION OF SUITABLE WETTED PARTS AND FILLING FLUID FOR COMPATIBILITY WITH THE PROCESS MEDIA IS A CUSTOMER'S RESPONSIBILITY, IF NOT OTHERWISE NOTIFIED BEFORE MANUFACTURING.

NACE CONFORMITY IS ACCORDING TO RECOMMENDATIONS PER MR0175.AISI 316 AND HASTELLOY C-276 ALSO COMPLY WITH MR0103 IF ALREADY WITH MR0175.

**BASIC ORDERING INFORMATION model S26RA Rotating flange diaphragm seals (flush and extended) to ASME B16.5**

Select one character or set of characters from each category and specify complete catalog number.

BASE MODEL - 1 <sup>st</sup> to 5 <sup>th</sup> characters	S	2	6	R	A	X	XX	X	X	XX	X	X	X	X
Rotating flange diaphragm seal (flush and extended) to ASME B16.5														
<b>Transmitter Side of Connection - 6<sup>th</sup> character</b>														
High pressure side						H								
Low pressure side						L								
<b>Mounting Flange Rating / Size - 7<sup>th</sup> and 8<sup>th</sup> characters</b>														
ASME CL 150 / 2 in.							E1							
ASME CL 300 / 2 in.							E2							
ASME CL 600 / 2 in.							E3							
ASME CL 900-1500 / 2 in.							E5							
ASME CL 150 / 3 in.							G1							
ASME CL 300 / 3 in.							G2							
ASME CL 600 / 3 in.							G3							
ASME CL 900 / 3 in.							G4							
ASME CL 1500 / 3 in.							G5							
ASME CL 150 / 4 in.							H1							
ASME CL 300 / 4 in.							H2							
<b>Mounting Flange Material - 9<sup>th</sup> character</b>														
Carbon steel								C						
AISI 316 ss								S						
<b>Extensions Length and Material - 10<sup>th</sup> character</b>														
Flush													F	
50 mm (2 in.)				AISI 316 L ss	(Note 1)									1
50 mm (2 in.)				Hastelloy C-276	(Note 1)									2
100 mm (4 in.)				AISI 316 L ss	(Note 1)									3
100 mm (4 in.)				Hastelloy C-276	(Note 1)									4
150 mm (6 in.)				AISI 316 L ss	(Note 1)									5
150 mm (6 in.)				Hastelloy C-276	(Note 1)									6
<b>Diaphragm Material - 11<sup>th</sup> and 12<sup>th</sup> characters</b>														
AISI 316 L ss				(Note 2)			NACE							SM
AISI 316 L ss - Low thickness (not for extended diaphragm)				(Note 3)			NACE							SL
Hastelloy C-276							NACE							HM
Hastelloy C-276 - Low thickness (not for extended diaphragm)				(Note 3)			NACE							HL
Hastelloy C-2000 (not for extended diaphragm)				(Note 3)			NACE							MM
Hastelloy C-2000 diaphragm and body (not for extended diaphragm)				(Note 3)			NACE							ZM
Inconel 625 (not for extended diaphragm)				(Note 3)			NACE							LM
Tantalum (not for extended diaphragm)				(Note 3)										TM
AISI 316 L ss gold plated (not for extended diaphragm)				(Note 3)			NACE							NM
AISI 316 L ss with Teflon anti-stick coating				(Note 2)			NACE							KM
Hastelloy C-276 with Teflon anti-stick coating							NACE							YM
AISI 316 L ss with Teflon coating anti-corrosion and anti-stick				(Note 2)			NACE							WM
Diaflex (AISI with anti-abrasion treatment)				(Note 2)			NACE							FM
Superduplex ss (UNS S32750 to ASTM SA479) (not for extended diaphragm)				(Note 3)			NACE							EM

continued  
see next page

# Model 266DDH Differential

## Model 266HDH Gauge

## Model 266NDH Absolute

BASIC ORDERING INFORMATION model S26RA		S 2 6 R A X XX X X XX	X	X	X	X	X	X	X
<b>Seal Surface Finish - 13<sup>th</sup> character</b>									
Serrated	(Note 4)	1							
Smooth	(Note 15)	2							
<b>Capillary Protection - 14<sup>th</sup> character</b>									
AISI 316 L ss armour									
AISI 316 L ss armour with PVC protective cover									
Extension tube for direct mount seal	(Note 5)								
<b>Capillary Length m (Feet) - 15<sup>th</sup> character</b>									
Direct-mount construction	(Note 6)								
1 (3)	(Note 7)								
1.5 (5)	(Note 7)								
2 (7)	(Note 7)								
2.5 (8)	(Note 7)								
3 (10)	(Note 7)								
3.5 (12)	(Note 7)								
4 (13)	(Note 7)								
4.5 (15)	(Note 7)								
5 (17)	(Note 7)								
5.5 (18)	(Note 7)								
6 (20)	(Note 7)								
6.5 (22)	(Note 7)								
7 (23.5)	(Note 7)								
7.5 (25)	(Note 7)								
8 (27)	(Note 7)								
9 (30)	(Note 7)								
10 (33)	(Note 7)								
12 (40)	(Note 7)								
14 (47)	(Note 7)								
16 (53)	(Note 7)								
<b>Fill Fluid - 16<sup>th</sup> character</b>									
Silicone oil DC200 10 cSt									
Silicone oil Baysilone PD5 5 cSt									
Inert oil - Galden G5	(Note 8)								
Inert oil - Halocarbon 4.2	(Note 8)								
Silicone oil DC704									
Silicone polymer Syltherm XLT									
Mineral oil Esso Marcol 122 (FDA approved)	(Note 9)								
Vegetable oil Neobee M-20 (FDA approved)	(Note 9)								
Glycerin-water 70% (FDA approved)	(Note 9)								

continued  
see next page

BASIC ORDERING INFORMATION model S26RA			S 2 6 R A X XX X X XX X X X X	X	X	X
<b>Flushing Ring: Hole and Thread - 17<sup>th</sup> character</b>						
None (TO BE SELECTED FOR EXTENDED VERSIONS)				N		
1 hole - 1/2 in. NPT	(Note 3)			2		
2 holes - 1/2 in. NPT	(Note 3)			3		
1 hole - 1/4 in. NPT	(Note 3)			4		
2 holes - 1/4 in. NPT	(Note 3)			5		
<b>Flushing Ring Material - 18<sup>th</sup> character</b>						
None	(Note 10)				N	
AISI 316 L ss	(Note 11)	NACE				A
Hastelloy C-276	(Notes 11, 12)	NACE				H
<b>Flushing Ring: Plug and Gasket - 19<sup>th</sup> character</b>						
No plug - No gasket						N
No plug - garlock	(Note 11)					A
No plug - PTFE	(Note 11)					B
No plug - graphite	(Note 11)					C
AISI 316 L ss - no gasket	(Notes 11, 13)	NACE				D
AISI 316 L ss - garlock	(Notes 11, 13)	NACE				E
AISI 316 L ss - PTFE	(Notes 11, 13)	NACE				F
AISI 316 L ss - graphite	(Notes 11, 13)	NACE				G
Hastelloy C-276 - no gasket	(Notes 11, 14)	NACE				H
Hastelloy C-276 - garlock	(Notes 11, 14)	NACE				L
Hastelloy C-276 - PTFE	(Notes 11, 14)	NACE				M
Hastelloy C-276 - graphite	(Notes 11, 14)	NACE				P

- Note 1: Not available with mounting flange rating code E3, E5, G3, G4, G5  
Note 2: Not available with extensions length and material code 2, 4, 6  
Note 3: Not available with extensions length and material code 1, 2, 3, 4, 5, 6  
Note 4: Not available with diaphragm material code MM, LM, TM, NM, KM, YM, WM  
Note 5: Not available with transmitter side of connection code L  
Note 6: Not available with capillary protection code A, B  
Note 7: Not available with capillary protection code N  
Note 8: Suitable for oxygen service  
Note 9: Suitable for food application  
Note 10: Not available with Flushing ring: hole and thread code 2, 3, 4, 5  
Note 11: Not available with Flushing ring: hole and thread code N  
Note 12: Not available with Seal surface finish code 1  
Note 13: Not available with Hastelloy C-276 flushing ring material code H  
Note 14: Not available with AISI 316 L flushing ring material code A  
Note 15: Not available with diaphragm material code ZM

# Model 266DDH Differential

## Model 266HDH Gauge

## Model 266NDH Absolute

### BASIC ORDERING INFORMATION model S26RE Rotating flange diaphragm seals (flush and extended) to EN 1092-1

Select one character or set of characters from each category and specify complete catalog number.

BASE MODEL - 1 <sup>st</sup> to 5 <sup>th</sup> characters	S	2	6	R	E	X	XX	X	X	XX	X	X	X	X		
Rotating flange diaphragm seal (flush and extended) to EN 1092-1																
<b>Transmitter Side of Connection - 6<sup>th</sup> character</b>																
High pressure side						H										
Low pressure side						L										
<b>Mounting Flange Rating / Size - 7<sup>th</sup> and 8<sup>th</sup> characters</b>																
PN 16 - 40 / DN 50																
PN 63 / DN 50																
PN 100 / DN 50																
PN 16 / DN 80																
PN 40 / DN 80																
PN 63 / DN 80																
PN 100 / DN 80																
PN 16 / DN 100																
PN 40 / DN 100																
<b>Mounting Flange Material - 9<sup>th</sup> character</b>																
Carbon steel																
AISI 316 ss																
<b>Extensions Length and Material - 10<sup>th</sup> character</b>																
Flush														F		
50 mm (2in)						AISI 316 L ss								(Note 1)	1	
50 mm (2in)						Hastelloy C-276								(Note 1)	2	
100 mm (4in)						AISI 316 L ss								(Note 1)	3	
100 mm (4in)						Hastelloy C-276								(Note 1)	4	
150 mm (6 in)						AISI 316 L ss								(Note 1)	5	
150 mm (6 in)						Hastelloy C-276								(Note 1)	6	
<b>Diaphragm Material - 11<sup>th</sup> and 12<sup>th</sup> characters</b>																
AISI 316 L ss														(Note 2)	NACE	SM
AISI 316 L ss - Low thickness (not for extended diaphragm)														(Note 3)	NACE	SL
Hastelloy C-276															NACE	HM
Hastelloy C-276 - Low thickness (not for extended diaphragm)														(Note 3)	NACE	HL
Hastelloy C-2000 (not for extended diaphragm)														(Note 3)	NACE	MM
Inconel 625 (not for extended diaphragm)														(Note 3)	NACE	LM
Tantalum (not for extended diaphragm)														(Note 3)	NACE	TM
AISI 316 L ss gold plated (not for extended diaphragm)														(Note 3)	NACE	NM
AISI 316 L ss with Teflon anti-stick coating														(Note 2)	NACE	KM
Hastelloy C-276 with Teflon anti-stick coating															NACE	YM
AISI 316 L ss with Teflon coating anti-corrosion and anti-stick														(Note 2)	NACE	WM
Diaflex (AISI with anti-abrasion treatment)														(Note 2)	NACE	FM
Superduplex ss (UNS S32750 to ASTM SA479) (not for extended diaphragm)														(Note 3)	NACE	EM

continued  
see next page

BASIC ORDERING INFORMATION model S26RE		S 2 6 R E X XX X X XX	X	X	X	X	X	X	X
<b>Seal Surface Finish - 13<sup>th</sup> character</b>									
Serrated	(Note 4)		1						
Smooth			2						
<b>Capillary Protection - 14<sup>th</sup> character</b>									
AISI 316 L ss armour				A					
AISI 316 L ss armour with PVC protective cover				B					
Extension tube for direct mount seal	(Note 5)			N					
<b>Capillary Length m (Feet) - 15<sup>th</sup> character</b>									
Direct-mount construction	(Note 6)						1		
1 (3)	(Note 7)						A		
1.5 (5)	(Note 7)						B		
2 (7)	(Note 7)						C		
2.5 (8)	(Note 7)						D		
3 (10)	(Note 7)						E		
3.5 (12)	(Note 7)						F		
4 (13)	(Note 7)						G		
4.5 (15)	(Note 7)						H		
5 (17)	(Note 7)						J		
5.5 (18)	(Note 7)						K		
6 (20)	(Note 7)						L		
6.5 (22)	(Note 7)						M		
7 (23.5)	(Note 7)						N		
7.5 (25)	(Note 7)						P		
8 (27)	(Note 7)						Q		
9 (30)	(Note 7)						R		
10 (33)	(Note 7)						S		
12 (40)	(Note 7)						T		
14 (47)	(Note 7)						U		
16 (53)	(Note 7)						V		
<b>Fill Fluid - 16th character</b>									
Silicone oil DC200 10 cSt								S	
Silicone oil Baysilone PD5 5 cSt								P	
Inert oil - Galden G5	(Note 8)							N	
Inert oil - Halocarbon 4.2	(Note 8)							D	
Silicone oil DC704								G	
Silicone polymer Syltherm XLT								C	
Mineral oil Esso Marcol 122 (FDA approved)	(Note 9)							W	
Vegetable oil Neobee M-20 (FDA approved)	(Note 9)							A	
Glycerin-water 70% (FDA approved)	(Note 9)							B	

continued  
see next page

# Model 266DDH Differential

## Model 266HDH Gauge

## Model 266NDH Absolute

BASIC ORDERING INFORMATION model S26RE		S	2	6	R	E	X	XX	XX	XX	XX	XX	X	X	X
<b>Flushing Ring: Hole and Thread</b> - 17 <sup>th</sup> character															
None (TO BE SELECTED FOR EXTENDED VERSIONS)													N		
1 hole - 1/2 in. NPT (Note 3)													2		
2 holes - 1/2 in. NPT (Note 3)													3		
1 hole - 1/4 in. NPT (Note 3)													4		
2 holes - 1/4 in. NPT (Note 3)													5		
<b>Flushing Ring Material</b> - 18 <sup>th</sup> character															
None (Note 10)														N	
AISI 316 L ss (Note 11)															A
Hastelloy C-276 (Notes 11, 12)															H
<b>Flushing Ring: Plug and Gasket</b> - 19 <sup>th</sup> character															
No plug - No gasket															N
No plug - garlock (Note 11)															A
No plug - PTFE (Note 11)															B
No plug - graphite (Note 11)															C
AISI 316 L ss - no gasket (Notes 11, 13)															D
AISI 316 L ss - garlock (Notes 11, 13)															E
AISI 316 L ss - PTFE (Notes 11, 13)															F
AISI 316 L ss - graphite (Notes 11, 13)															G
Hastelloy C-276 - no gasket (Notes 11, 14)															H
Hastelloy C-276 - garlock (Notes 11, 14)															L
Hastelloy C-276 - PTFE (Notes 11, 14)															M
Hastelloy C-276 - graphite (Notes 11, 14)															P

- Note 1: Not available with mounting flange rating code N3, N4, P3, P4
- Note 2: Not available with extensions length and material code 2, 4, 6
- Note 3: Not available with extensions length and material code 1, 2, 3, 4, 5, 6
- Note 4: Not available with diaphragm material code MM, LM, TM, NM, KM, YM, WM
- Note 5: Not available with transmitter side of connection code L
- Note 6: Not available with capillary protection code A, B
- Note 7: Not available with capillary protection code N
- Note 8: Suitable for oxygen service
- Note 9: Suitable for food application
- Note 10: Not available with Flushing ring: hole and thread code 2, 3, 4, 5
- Note 11: Not available with Flushing ring: hole and thread code N
- Note 12: Not available with Seal surface finish code 1
- Note 13: Not available with Hastelloy C-276 flushing ring material code H
- Note 14: Not available with AISI 316 L flushing ring material code A

**BASIC ORDERING INFORMATION model S26FA Fixed flange diaphragm seals (flush) to ASME B16.5**

Select one character or set of characters from each category and specify complete catalog number.

<b>BASE MODEL</b> - 1 <sup>st</sup> to 5 <sup>th</sup> characters	S	2	6	F	A	X	XX	X	X	XX	X	X	X	X
Fixed flange diaphragm seal (flush) to ASME B16.5														
<b>Transmitter Side of Connection</b> - 6 <sup>th</sup> character														
High pressure side						H								
Low pressure side						L								
<b>Mounting Flange Rating / Size</b> - 7 <sup>th</sup> and 8 <sup>th</sup> characters														
ASME CL 150 / 2 in.							E1							
ASME CL 300 / 2 in.							E2							
ASME CL 600 / 2 in.							E3							
ASME CL 150 / 3 in.							G1							
ASME CL 300 / 3 in.							G2							
ASME CL 600 / 3 in.							G3							
ASME CL 150 / 4 in.							H1							
<b>Mounting Flange Material</b> - 9 <sup>th</sup> character														
AISI 316 ss										S				
<b>Extensions Length</b> - 10 <sup>th</sup> character														
Flush											F			
<b>Diaphragm Material</b> - 11 <sup>th</sup> and 12 <sup>th</sup> characters														
AISI 316 L ss								NACE					SM	
AISI 316 L ss - Low thickness								NACE					SL	
Hastelloy C-276								NACE					HM	
Hastelloy C-276 - Low thickness								NACE					HL	
Hastelloy C-2000								NACE					MM	
Inconel 625								NACE					LM	

X	X	X	X
---	---	---	---

continued  
see next page

# Model 266DDH Differential

## Model 266HDH Gauge

## Model 266NDH Absolute

BASIC ORDERING INFORMATION model S26FA		S	2	F	A	X	X	X	X	X	X	X
<b>Seal Surface Finish - 13<sup>th</sup> character</b>												
Serrated	(Note 1)					1						
Smooth						2						
<b>Capillary Protection - 14<sup>th</sup> character</b>												
AISI 316 L ss armour												
AISI 316 L ss armour with PVC protective cover												
Extension tube for direct mount seal	(Note 2)											
<b>Capillary Length m (Feet) - 15<sup>th</sup> character</b>												
Direct-mount construction	(Note 3)											1
1 (3)	(Note 4)											A
1.5 (5)	(Note 4)											B
2 (7)	(Note 4)											C
2.5 (8)	(Note 4)											D
3 (10)	(Note 4)											E
3.5 (12)	(Note 4)											F
4 (13)	(Note 4)											G
4.5 (15)	(Note 4)											H
5 (17)	(Note 4)											J
5.5 (18)	(Note 4)											K
6 (20)	(Note 4)											L
6.5 (22)	(Note 4)											M
7 (23.5)	(Note 4)											N
7.5 (25)	(Note 4)											P
8 (27)	(Note 4)											Q
9 (30)	(Note 4)											R
10 (33)	(Note 4)											S
12 (40)	(Note 4)											T
14 (47)	(Note 4)											U
16 (53)	(Note 4)											V
<b>Fill Fluid - 16<sup>th</sup> character</b>												
Silicone oil DC200 10 cSt												S
Silicone oil Baysilone PD5 5 cSt												P
Inert oil - Galden G5	(Note 5)											N
Inert oil - Halocarbon 4.2	(Note 5)											D
Silicone oil DC704												G
Silicone polymer Syltherm XLT												C
Mineral oil Esso Marcol 122 (FDA approved)	(Note 6)											W
Vegetable oil Neobee M-20 (FDA approved)	(Note 6)											A
Glycerin-water 70% (FDA approved)	(Note 6)											B

continued  
see next page

BASIC ORDERING INFORMATION model S26FA		S 2 6 F A X XX X X XX X X X X X			X	X	X
<b>Flushing Ring: Hole and Thread - 17<sup>th</sup> character</b>							
None					N		
1 hole - 1/2 in. NPT					2		
2 holes - 1/2 in. NPT					3		
1 hole - 1/4 in. NPT					4		
2 holes - 1/4 in. NPT					5		
<b>Flushing Ring Material - 18<sup>th</sup> character</b>							
None	(Note 7)					N	
AISI 316 L ss	(Note 8)		NACE			A	
Hastelloy C-276	(Notes 8, 9)		NACE			H	
<b>Flushing Ring: Plug and Gasket - 19<sup>th</sup> character</b>							
No plug - No gasket							N
No plug - garlock	(Note 8)						A
No plug - PTFE	(Note 8)						B
No plug - graphite	(Note 8)						C
AISI 316 L ss - no gasket	(Notes 8, 10)		NACE				D
AISI 316 L ss - garlock	(Notes 8, 10)		NACE				E
AISI 316 L ss - PTFE	(Notes 8, 10)		NACE				F
AISI 316 L ss - graphite	(Notes 8, 10)		NACE				G
Hastelloy C-276 - no gasket	(Notes 8, 11)		NACE				H
Hastelloy C-276 - garlock	(Notes 8, 11)		NACE				L
Hastelloy C-276 - PTFE	(Notes 8, 11)		NACE				M
Hastelloy C-276 - graphite	(Notes 8, 11)		NACE				P

- Note 1: Not available with diaphragm material code MM, LM
- Note 2: Not available with transmitter side of connection code L
- Note 3: Not available with capillary protection code A, B
- Note 4: Not available with capillary protection code N
- Note 5: Suitable for oxygen service
- Note 6: Suitable for food application
- Note 7: Not available with Flushing ring: hole and thread code 2, 3, 4, 5
- Note 8: Not available with Flushing ring: hole and thread code N
- Note 9: Not available with Seal surface finish code 1
- Note 10: Not available with Hastelloy C-276 flushing ring material code H
- Note 11: Not available with AISI 316 L flushing ring material code A

# Model 266DDH Differential

## Model 266HDH Gauge

## Model 266NDH Absolute

### BASIC ORDERING INFORMATION model S26FE Fixed flange diaphragm seals (flush) to EN 1092-1

Select one character or set of characters from each category and specify complete catalog number.

BASE MODEL - 1 <sup>st</sup> to 5 <sup>th</sup> characters	S	2	6	F	E	X	XX	X	X	XX	X	X	X	X
Fixed flange diaphragm seal (flush) to EN 1092-1														
<b>Transmitter Side of Connection - 6<sup>th</sup> character</b>														
High pressure side						H								
Low pressure side						L								
<b>Mounting Flange Rating / Size - 7<sup>th</sup> and 8<sup>th</sup> characters</b>														
PN 16 / DN 50							N1							
PN 40 / DN 50							N2							
PN 63 / DN 50							N3							
PN 100 / DN 50							N4							
PN 16 / DN 80							P1							
PN 40 / DN 80							P2							
PN 63 / DN 80							P3							
PN 100 / DN 80							P4							
PN 16 / DN 100							Q1							
<b>Mounting Flange Material - 9<sup>th</sup> character</b>														
AISI 316 ss									S					
<b>Extensions Length - 10<sup>th</sup> character</b>														
Flush										F				
<b>Diaphragm Material - 11<sup>th</sup> and 12<sup>th</sup> characters</b>														
AISI 316 L ss							NACE						SM	
AISI 316 L ss - Low thickness (not for extended diaphragm)							NACE						SL	
Hastelloy C-276							NACE						HM	
Hastelloy C-276 - Low thickness (not for extended diaphragm)							NACE						HL	
Hastelloy C-2000 (not for extended diaphragm)							NACE						MM	
Inconel 625 (not for extended diaphragm)							NACE						LM	

continued  
see next page



# Model 266DDH Differential

## Model 266HDH Gauge

## Model 266NDH Absolute

BASIC ORDERING INFORMATION model S26FE			S	2	6	F	E	X	XX	X	X	XX	X	X	X	X	X	X
<b>Flushing Ring: Hole and Thread - 17<sup>th</sup> character</b>																		
None																	N	
1 hole - 1/2 in. NPT		(Note 9)															2	
2 holes - 1/2 in. NPT		(Note 9)															3	
1 hole - 1/4 in. NPT		(Note 9)															4	
2 holes - 1/4 in. NPT		(Note 9)															5	
<b>Flushing Ring Material - 18<sup>th</sup> character</b>																		
None		(Note 10)																N
AISI 316 L ss		(Note 11)																A
Hastelloy C-276		(Notes 11, 12)																H
<b>Flushing Ring: Plug and Gasket - 19<sup>th</sup> character</b>																		
No plug - No gasket																		N
No plug - garlock		(Note 11)																A
No plug - PTFE		(Note 11)																B
No plug - graphite		(Note 11)																C
AISI 316 L ss - no gasket		(Notes 11, 13)																D
AISI 316 L ss - garlock		(Notes 11, 13)																E
AISI 316 L ss - PTFE		(Notes 11, 13)																F
AISI 316 L ss - graphite		(Notes 11, 13)																G
Hastelloy C-276 - no gasket		(Notes 11, 14)																H
Hastelloy C-276 - garlock		(Notes 11, 14)																L
Hastelloy C-276 - PTFE		(Notes 11, 14)																M
Hastelloy C-276 - graphite		(Notes 11, 14)																P

- Note 1: Not available with diaphragm material code MM, LM
- Note 2: Not available with DN 100 size code Q1 combined with diaphragm material code SM, HM, HL, MM, LM
- Note 3: Not available with diaphragm material code HM, HL, MM, LM
- Note 4: Not available with transmitter side of connection code L
- Note 5: Not available with capillary protection code A, B
- Note 6: Not available with capillary protection code N
- Note 7: Suitable for oxygen service
- Note 8: Suitable for food application
- Note 9: Not available with Seal surface finish code 4, 6
- Note 10: Not available with Flushing ring: hole and thread code 2, 3, 4, 5
- Note 11: Not available with Flushing ring: hole and thread code N
- Note 12: Not available with Seal surface finish code 1
- Note 13: Not available with Hastelloy C-276 flushing ring material code H
- Note 14: Not available with AISI 316 L flushing ring material code A

**BASIC ORDERING INFORMATION model S26RJ Rotating flange diaphragm seals (flush) to JIS**

Select one character or set of characters from each category and specify complete catalog number.

<b>BASE MODEL</b> - 1 <sup>st</sup> to 5 <sup>th</sup> characters	S	2	6	R	J	X	XX	X	X	XX	X	X	X	X	X	X	X	X
Rotating flange diaphragm seal (flush) to JIS																		
<b>Transmitter Side of Connection</b> - 6 <sup>th</sup> character																		
High pressure side																		
Low pressure side																		
<b>Mounting Flange Rating / Size</b> - 7 <sup>th</sup> and 8 <sup>th</sup> characters																		
10K / A50																		
20K / A50																		
40K / A50																		
10K / A80																		
20K / A80																		
40K / A80																		
10K / A100																		
20K / A100																		
<b>Mounting Flange Material</b> - 9 <sup>th</sup> character																		
Carbon steel																		
AISI 316 ss																		
<b>Extensions Length</b> - 10 <sup>th</sup> character																		
Flush																		
<b>Diaphragm Material</b> - 11 <sup>th</sup> and 12 <sup>th</sup> characters																		
AISI 316 L ss																		
Hastelloy C-276																		
Hastelloy C-2000																		
Inconel 625																		
Tantalum																		
AISI 316 L ss gold plated																		
AISI 316 L ss with Teflon anti-stick coating																		
Hastelloy C-276 with Teflon anti-stick coating																		
AISI 316 L ss with Teflon coating anti-corrosion and anti-stick																		
Superduplex ss (UNS S32750 to ASTM SA479)																		
<b>Seal Surface Finish</b> - 13 <sup>th</sup> character																		
Serrated (Note 1)																		1
Smooth																		2
<b>Capillary Protection</b> - 14 <sup>th</sup> character																		
AISI 316 L ss armour																		A
AISI 316 L ss armour with PVC protective cover																		B
Extension tube for direct mount seal (Note 2)																		N

continued  
see next page

# Model 266DDH Differential

## Model 266HDH Gauge

## Model 266NDH Absolute

BASIC ORDERING INFORMATION model S26RJ		S	2	6	R	J	X	XX	XX	XX	XX	X	X	X	X	X
<b>Capillary Length m (Feet) - 15<sup>th</sup> character</b>																
Direct-mount construction	(Note 3)											1				
1 (3)	(Note 4)											A				
1.5 (5)	(Note 4)											B				
2 (7)	(Note 4)											C				
2.5 (8)	(Note 4)											D				
3 (10)	(Note 4)											E				
3.5 (12)	(Note 4)											F				
4 (13)	(Note 4)											G				
4.5 (15)	(Note 4)											H				
5 (17)	(Note 4)											J				
5.5 (18)	(Note 4)											K				
6 (20)	(Note 4)											L				
6.5 (22)	(Note 4)											M				
7 (23.5)	(Note 4)											N				
7.5 (25)	(Note 4)											P				
8 (27)	(Note 4)											Q				
9 (30)	(Note 4)											R				
10 (33)	(Note 4)											S				
12 (40)	(Note 4)											T				
14 (47)	(Note 4)											U				
16 (53)	(Note 4)											V				
<b>Fill Fluid - 16<sup>th</sup> character</b>																
Silicone oil DC200 10 cSt													S			
Silicone oil Baysilone PD5 5 cSt													P			
Inert oil - Galden G5	(Note 5)												N			
Inert oil - Halocarbon 4.2	(Note 5)												D			
Silicone oil DC704													G			
Silicone polymer Syltherm XLT													C			
Mineral oil Esso Marcol 122 (FDA approved)	(Note 6)												W			
Vegetable oil Neobee M-20 (FDA approved)	(Note 6)												A			
Glycerin-water 70% (FDA approved)	(Note 6)												B			
<b>Flushing Ring: Hole and Thread - 17<sup>th</sup> character</b>																
None																N
<b>Flushing Ring Material - 18<sup>th</sup> character</b>																
None																N
<b>Flushing Ring: Hole and Thread - 19<sup>th</sup> character</b>																
None																N

Note 1: Not available with diaphragm material code HM, MM, LM, TN, NM, KM, YM, WM  
 Note 2: Not available with transmitter side of connection code L  
 Note 3: Not available with capillary protection code A, B  
 Note 4: Not available with capillary protection code N  
 Note 5: Suitable for oxygen service  
 Note 6: Suitable for food application

**BASIC ORDERING INFORMATION model S26RR Rotating flange diaphragm seals (flush) - Ring Joint**

Select one character or set of characters from each category and specify complete catalog number.

<b>BASE MODEL</b> - 1 <sup>st</sup> to 5 <sup>th</sup> characters	S	2	6	R	R	X	XX	X	X	XX	X	X	X	X	X	X	X	X
Rotating flange diaphragm seal (flush) Ring Joint to ASME B16.5																		
<b>Transmitter Side of Connection</b> - 6 <sup>th</sup> character																		
High pressure side						H												
Low pressure side						L												
<b>Mounting Flange Rating / Size</b> - 7 <sup>th</sup> and 8 <sup>th</sup> characters																		
ASME CL 150 / 1 1/2 in.																		
ASME CL 300 / 1 1/2 in.																		
ASME CL 600 / 1 1/2 in.																		
ASME CL 900-1500 / 1 1/2 in.																		
ASME CL 150 / 2 in.																		
ASME CL 300 / 2 in.																		
ASME CL 600 / 2 in.																		
ASME CL 900-1500 / 2 in.																		
ASME CL 150 / 3 in.																		
ASME CL 300 / 3 in.																		
ASME CL 600 / 3 in.																		
ASME CL 900 / 3 in.																		
ASME CL 1500 / 3 in.																		
<b>Mounting Flange Material</b> - 9 <sup>th</sup> character																		
Carbon steel																		
AISI 316 ss																		
<b>Extensions Length</b> - 10 <sup>th</sup> character																		
Flush																		
<b>Diaphragm Material</b> - 11 <sup>th</sup> and 12 <sup>th</sup> characters																		
AISI 316 L ss																		
Hastelloy C-276																		
Inconel 625																		
<b>Seal Surface Finish</b> - 13 <sup>th</sup> character																		
Ring joint																		
<b>Capillary Protection</b> - 14 <sup>th</sup> character																		
AISI 316 L ss armour																		
AISI 316 L ss armour with PVC protective cover																		
Extension tube for direct mount seal (Note 1)																		

X X X X  
continued  
see next page

# Model 266DDH Differential

## Model 266HDH Gauge

## Model 266NDH Absolute

BASIC ORDERING INFORMATION model S26RR		S	2	6	R	R	X	XX	XX	XX	XX	X	X	X	X	X
<b>Capillary Length m (Feet) - 15<sup>th</sup> character</b>																
Direct-mount construction	(Note 2)											1				
1 (3)	(Note 3)											A				
1.5 (5)	(Note 3)											B				
2 (7)	(Note 3)											C				
2.5 (8)	(Note 3)											D				
3 (10)	(Note 3)											E				
3.5 (12)	(Note 3)											F				
4 (13)	(Note 3)											G				
4.5 (15)	(Note 3)											H				
5 (17)	(Note 3)											J				
5.5 (18)	(Note 3)											K				
6 (20)	(Note 3)											L				
6.5 (22)	(Note 3)											M				
7 (23.5)	(Note 3)											N				
7.5 (25)	(Note 3)											P				
8 (27)	(Note 3)											Q				
9 (30)	(Note 3)											R				
10 (33)	(Note 3)											S				
12 (40)	(Note 3)											T				
14 (47)	(Note 3)											U				
16 (53)	(Note 3)											V				
<b>Fill Fluid - 16<sup>th</sup> character</b>																
Silicone oil DC200 10 cSt													S			
Silicone oil Baysilone PD5 5 cSt													P			
Inert oil - Galden G5	(Note 4)												N			
Inert oil - Halocarbon 4.2	(Note 4)												D			
Silicone oil DC704													G			
Silicone polymer Syltherm XLT													C			
Mineral oil Esso Marcol 122 (FDA approved)	(Note 5)												W			
Vegetable oil Neobee M-20 (FDA approved)	(Note 5)												A			
Glycerin-water 70% (FDA approved)	(Note 5)												B			
<b>Flushing Ring: Hole and Thread - 17<sup>th</sup> character</b>																
None																N
<b>Flushing Ring Material - 18<sup>th</sup> character</b>																
None																N
<b>Flushing Ring: Hole and Thread - 19<sup>th</sup> character</b>																
None																N

Note 1: Not available with transmitter side of connection code L  
 Note 2: Not available with capillary protection code A, B  
 Note 3: Not available with capillary protection code N  
 Note 4: Suitable for oxygen service  
 Note 5: Suitable for food application

**BASIC ORDERING INFORMATION model S26MA Off-line flange diaphragm seals**

Select one character or set of characters from each category and specify complete catalog number.

BASE MODEL - 1 <sup>st</sup> to 5 <sup>th</sup> characters	S	2	6	M	A	X	XX	X	XX	X	X	X	X	X
Off-line flange diaphragm seal to ASME B16.5														
<b>Transmitter Side of Connection - 6<sup>th</sup> character</b>														
High pressure side						H								
Low pressure side						L								
<b>Mounting Flange Rating / Size - 7<sup>th</sup> and 8<sup>th</sup> characters</b>														
ASME CL 150 / 1/2 in.														A1
ASME CL 300 / 1/2 in.														A2
ASME CL 150 / 1 in.														C1
ASME CL 300 / 1 in.														C2
ASME CL 150 / 1 1/2 in.														D1
ASME CL 300 / 1 1/2 in.														D2
<b>Mounting Flange Material / Seat Form - 9<sup>th</sup> character</b>														
AISI 316 ss / Form RF (raised face) - serrated finish														S
Hastelloy C-276 / Form RF (raised face) - serrated finish														H
Hastelloy C-2000 / Form RF (raised face) - serrated finish														Y
<b>Diaphragm Material - 10<sup>th</sup> and 11<sup>th</sup> characters</b>														
AISI 316 L ss														NACE
Hastelloy C-276														NACE
Hastelloy C-2000														NACE
Hastelloy C-2000 diaphragm and body														NACE
Inconel 625														NACE
Tantalum														NACE
AISI 316 L ss gold plated														NACE
<b>Capillary Protection - 12<sup>th</sup> character</b>														
AISI 316 L ss armour														A
AISI 316 L ss armour with PVC protective cover														B
Extension tube for direct mount seal														(Note 1) N

continued  
see next page

# Model 266DDH Differential

## Model 266HDH Gauge

## Model 266NDH Absolute

BASIC ORDERING INFORMATION model S26MA		S	2	6	M	A	X	XX	X	XX	X	X	X	X
<b>Capillary Length m (Feet) - 13<sup>th</sup> character</b>														
Direct-mount construction	(Note 2)											1		
1 (3)	(Note 3)											A		
1.5 (5)	(Note 3)											B		
2 (7)	(Note 3)											C		
2.5 (8)	(Note 3)											D		
3 (10)	(Note 3)											E		
3.5 (12)	(Note 3)											F		
4 (13)	(Note 3)											G		
4.5 (15)	(Note 3)											H		
5 (17)	(Note 3)											J		
5.5 (18)	(Note 3)											K		
6 (20)	(Note 3)											L		
6.5 (22)	(Note 3)											M		
7 (23.5)	(Note 3)											N		
7.5 (25)	(Note 3)											P		
8 (27)	(Note 3)											Q		
9 (30)	(Note 3)											R		
10 (33)	(Note 3)											S		
12 (40)	(Note 3)											T		
<b>Fill Fluid - 14<sup>th</sup> character</b>														
Silicone oil DC200 10 cSt													S	
Silicone oil Baysilone PD5 5 cSt													P	
Inert oil - Galden G5	(Note 4)												N	
Inert oil - Halocarbon 4.2	(Note 4)												D	
Silicone oil DC704													G	
Silicone polymer Syltherm XLT													C	
Mineral oil Esso Marcol 122 (FDA approved)	(Note 5)												W	
Vegetable oil Neobee M-20 (FDA approved)	(Note 5)												A	
Glycerin-water 70% (FDA approved)	(Note 5)												B	
<b>Flushing Connections - 15<sup>th</sup> character</b>														
Not required														1
Provided														Q
<b>Gasket - 16<sup>th</sup> character</b>														
PTFE														2
Viton™	(Note 6)													3
Graphite	(Note 6)													7

Note 1: Not available with transmitter side of connection code L  
 Note 2: Not available with capillary protection code A, B  
 Note 3: Not available with capillary protection code N  
 Note 4: Suitable for oxygen service  
 Note 5: Suitable for food application  
 Note 6: Not available with diaphragm material code ZM  
 Note 7: Not available with diaphragm material code SM, HM, MM, LM, TM, NM

**BASIC ORDERING INFORMATION model S26ME Off-line flange diaphragm seals**

Select one character or set of characters from each category and specify complete catalog number.

BASE MODEL - 1 <sup>st</sup> to 5 <sup>th</sup> characters	S	2	6	M	E	X	XX	X	XX	X	X	X	X
Off-line flange diaphragm seal to EN 1092-1													
<b>Transmitter Side of Connection - 6<sup>th</sup> character</b>													
High pressure side						H							
Low pressure side						L							
<b>Mounting Flange Rating / Size - 7<sup>th</sup> and 8<sup>th</sup> characters</b>													
PN 16 - 40 / DN 25								L2					
PN 16 - 40 / DN 40								M2					
<b>Mounting Flange Material / Seat Form - 9<sup>th</sup> character</b>													
AISI 316 ss / Form RF (raised face) - serrated finish						NACE			S				
Hastelloy C-276 / Form RF (raised face) - serrated finish						NACE			H				
<b>Diaphragm Material - 10<sup>th</sup> and 11<sup>th</sup> characters</b>													
AISI 316 L ss						NACE				SM			
Hastelloy C-276						NACE				HM			
Hastelloy C-2000						NACE				MM			
Inconel 625						NACE				LM			
Tantalum										TM			
AISI 316 L ss gold plated						NACE				NM			
<b>Capillary Protection - 12<sup>th</sup> character</b>													
AISI 316 L ss armour													A
AISI 316 L ss armour with PVC protective cover													B
Extension tube for direct mount seal (Note 1)													N

continued  
see next page

# Model 266DDH Differential

## Model 266HDH Gauge

## Model 266NDH Absolute

BASIC ORDERING INFORMATION model S26ME		S	2	6	M	E	X	XX	X	XX	X	X	X	X	
<b>Capillary Length m (Feet) - 13<sup>th</sup> character</b>												X	X	X	X
Direct-mount construction	(Note 2)											1			
1 (3)	(Note 3)											A			
1.5 (5)	(Note 3)											B			
2 (7)	(Note 3)											C			
2.5 (8)	(Note 3)											D			
3 (10)	(Note 3)											E			
3.5 (12)	(Note 3)											F			
4 (13)	(Note 3)											G			
4.5 (15)	(Note 3)											H			
5 (17)	(Note 3)											J			
5.5 (18)	(Note 3)											K			
6 (20)	(Note 3)											L			
6.5 (22)	(Note 3)											M			
7 (23.5)	(Note 3)											N			
7.5 (25)	(Note 3)											P			
8 (27)	(Note 3)											Q			
9 (30)	(Note 3)											R			
10 (33)	(Note 3)											S			
12 (40)	(Note 3)											T			
<b>Fill Fluid - 14<sup>th</sup> character</b>															
Silicone oil DC200 10 cSt												S			
Silicone oil Baysilone PD5 5 cSt												P			
Inert oil - Galden G5	(Note 4)											N			
Inert oil - Halocarbon 4.2	(Note 4)											D			
Silicone oil DC704												G			
Silicone polymer Syltherm XLT												C			
Mineral oil Esso Marcol 122 (FDA approved)	(Note 5)											W			
Vegetable oil Neobee M-20 (FDA approved)	(Note 5)											A			
Glycerin-water 70% (FDA approved)	(Note 5)											B			
<b>Flushing Connections - 15<sup>th</sup> character</b>															
Not required														1	
Provided														Q	
<b>Gasket - 16<sup>th</sup> character</b>															
PTFE														2	
Viton™														3	
Graphite														7	

Note 1: Not available with transmitter side of connection code L  
 Note 2: Not available with capillary protection code A, B  
 Note 3: Not available with capillary protection code N  
 Note 4: Suitable for oxygen service  
 Note 5: Suitable for food application

**BASIC ORDERING INFORMATION model S26TT Off-line threaded diaphragm seals**

Select one character or set of characters from each category and specify complete catalog number.

BASE MODEL - 1 <sup>st</sup> to 5 <sup>th</sup> characters	S	2	6	T	T	X	X	X	X	XX	X	X	X	X
Off-line threaded diaphragm seal														
<b>Transmitter Side of Connection - 6<sup>th</sup> character</b>														
High pressure side						H								
Low pressure side						L								
<b>Size - 7<sup>th</sup> character</b>														
1/4 in. NPT-f														
1/2 in. NPT-f														
3/4 in. NPT-f														
1 in. NPT-f														
1 1/2 in. NPT-f														
<b>Bolts material - 8<sup>th</sup> character</b>														
AISI 316 ss														
Carbon steel														
Alloy steel														
						NACE								
<b>Mounting Flange Material / Seat Form - 9<sup>th</sup> character</b>														
AISI 316 ss / Form RF (raised face) - serrated finish														
						NACE								
Hastelloy C-276 / Form RF (raised face) - serrated finish														
						NACE								
<b>Diaphragm Material - 10<sup>th</sup> and 11<sup>th</sup> characters</b>														
AISI 316 L ss														
						NACE								
Hastelloy C-276														
						NACE								
Hastelloy C-2000														
						NACE								
Inconel 625														
						NACE								
Tantalum														
						NACE								
AISI 316 L ss gold plated														
						NACE								
<b>Capillary Protection - 12<sup>th</sup> character</b>														
AISI 316 L ss armour														
AISI 316 L ss armour with PVC protective cover														
Extension tube for direct mount seal														
						(Note 1)								

continued  
see next page

# Model 266DDH Differential

## Model 266HDH Gauge

## Model 266NDH Absolute

BASIC ORDERING INFORMATION model S26TT		S	2	6	T	T	X	XX	X	XX	X	X	X	X
<b>Capillary Length m (Feet) - 13<sup>th</sup> character</b>														
Direct-mount construction	(Note 2)											1		
1 (3)	(Note 3)											A		
1.5 (5)	(Note 3)											B		
2 (7)	(Note 3)											C		
2.5 (8)	(Note 3)											D		
3 (10)	(Note 3)											E		
3.5 (12)	(Note 3)											F		
4 (13)	(Note 3)											G		
4.5 (15)	(Note 3)											H		
5 (17)	(Note 3)											J		
5.5 (18)	(Note 3)											K		
6 (20)	(Note 3)											L		
6.5 (22)	(Note 3)											M		
7 (23.5)	(Note 3)											N		
7.5 (25)	(Note 3)											P		
8 (27)	(Note 3)											Q		
9 (30)	(Note 3)											R		
10 (33)	(Note 3)											S		
12 (40)	(Note 3)											T		
<b>Fill Fluid - 14<sup>th</sup> character</b>														
Silicone oil DC200 10 cSt													S	
Silicone oil Baysilone PD5 5 cSt													P	
Inert oil - Galden G5	(Note 4)												N	
Inert oil - Halocarbon 4.2	(Note 4)												D	
Silicone oil DC704													G	
Silicone polymer Syltherm XLT													C	
Mineral oil Esso Marcol 122 (FDA approved)	(Note 5)												W	
Vegetable oil Neobee M-20 (FDA approved)	(Note 5)												A	
Glycerin-water 70% (FDA approved)	(Note 5)												B	
<b>Flushing Connections - 15<sup>th</sup> character</b>														
Not required														1
Provided	(Note 6)													Q
<b>Gasket - 16<sup>th</sup> character</b>														
PTFE														2
Viton™														3
Graphite														7

Note 1: Not available with transmitter side of connection code L  
 Note 2: Not available with capillary protection code A, B  
 Note 3: Not available with capillary protection code N  
 Note 4: Suitable for oxygen service  
 Note 5: Suitable for food application  
 Note 6: Not available with size code 5

**BASIC ORDERING INFORMATION model S26SS Sanitary and food diaphragm seals**

Select one character or set of characters from each category and specify complete catalog number.

BASE MODEL - 1 <sup>st</sup> to 5 <sup>th</sup> characters	S	2	6	S	S	X	X	XX	X	X	X	X	X
Sanitary and food diaphragm seal													
<b>Transmitter Side of Connection - 6<sup>th</sup> character</b>													
High pressure side						H							
Low pressure side						L							
<b>Mounting connection - 7<sup>th</sup> character</b>													
Union nut DIN 11851 – F50 (not 3-A authorized)													
Union nut DIN 11851 – F80 (not 3-A authorized)													
2 in. Triclamp													
3 in. Triclamp													
4 in. Triclamp													
2 in. Cherry Burrell													
3 in. Cherry Burrell													
4 in. Cherry Burrell													
4 in. Sanitary flush diaphragm													
4 in. Sanitary extended (2 in.) diaphragm													
4 in. Sanitary extended (4 in.) diaphragm													
4 in. Sanitary extended (6 in.) diaphragm													
Beverage application bolted seal (not 3-A authorized) - ONLY DIRECT MOUNT WITH 266HDH, 266NDH													
<b>Diaphragm Material - 8<sup>th</sup> and 9<sup>th</sup> characters</b>													
AISI 316 L ss													SM
<b>Capillary Protection - 10<sup>th</sup> character</b>													
AISI 316 L ss armour (Note 1)													A
AISI 316 L ss armour with PVC protective cover (Note 1)													B
Extension tube for direct mount seal (Note 2)													N
<b>Capillary Length m (Feet) - 11<sup>th</sup> character</b>													
Direct-mount construction (Note 3)													1
1 (3) (Note 4)													A
1.5 (5) (Note 4)													B
2 (7) (Note 4)													C
2.5 (8) (Note 4)													D
3 (10) (Note 4)													E
3.5 (12) (Note 4)													F
4 (13) (Note 4)													G
4.5 (15) (Note 4)													H
5 (17) (Note 4)													J
5.5 (18) (Note 4)													K
6 (20) (Note 4)													L
6.5 (22) (Note 4)													M
7 (23.5) (Note 4)													N
7.5 (25) (Note 4)													P
8 (27) (Note 4)													Q
9 (30) (Note 4)													R
10 (33) (Note 4)													S

continued  
see next page

# Model 266DDH Differential

## Model 266HDH Gauge

## Model 266NDH Absolute

BASIC ORDERING INFORMATION model S26SS		S	2	6	S	S	X	X	X	X	X	X	X	X
<b>Fill Fluid</b> - 12th character														
Silicone oil DC200 10 cSt													S	
Inert oil - Halocarbon 4.2	(Note 5)												D	
Silicone polymer Syltherm XLT													C	
Mineral oil Esso Marcol 122 (FDA approved)	(Note 6)												W	
Vegetable oil Neobee M-20 (FDA approved)	(Note 6)												A	
Glycerin-water 70% (FDA approved)	(Note 6)												B	
<b>Clamp/Fittings</b> - 13th character														
None														1
2 in. V-band Clamp (for 2 in. Triclamp)														A
3 in. V-band Clamp (for 3 in. Triclamp)														B
4 in. V-band Clamp (for 4 in. Triclamp, 4 in. Cherry Burrell and 4 in. Sanitary flush)														C
4 in. Tank spud, tank wall up to 4.7mm (0.18) and 4 in. V-band Clamp (for 4 in. Sanitary flush seal)														D
4 in. Tank spud, tank wall up to 9.5mm (0.37) and 4 in. V-band Clamp (for 4 in. Sanitary flush seal)														E
4 in. schedule 5 V-band clamp (for 4 in. Sanitary extended seal)														F
Tank spud for 2 in. extension and 4 in. schedule 5 V-band clamp (for 4 in. Sanitary extended 2 in. seal)														G
Tank spud for 4 in. extension and 4 in. schedule 5 V-band clamp (for 4 in. Sanitary extended 4 in. seal)														H
Tank spud for 6 in. extension and 4 in. schedule 5 V-band clamp (for 4 in. Sanitary extended 6 in. seal)														J
Flanged tank spud with 6 holes (for 1 1/2 in. beverage seal)														K
<b>Gasket</b> - 14th character														
None														1
Ethylene propylene gasket DN100 (for 4 in. Sanitary extended seal) - (EPDM 3-A 18-03 Class II)														A
Ethylene propylene gasket (for 1 1/2 in. beverage seal)														B
Ethylene propylene gasket DN50 (for F50 Union nut seal)														C
Ethylene propylene gasket DN80 (for F80 Union nut seal)														D
Ethylene propylene gasket (for 4 in. Sanitary flush) - (EPDM 3-A 18-03 Class II)														G

Note 1: Not available with beverage bolted seal connection code T  
 Note 2: Not available with transmitter side of connection code L  
 Note 3: Not available with capillary protection code A, B  
 Note 4: Not available with capillary protection code N  
 Note 5: Suitable for oxygen service  
 Note 6: Suitable for food application

**BASIC ORDERING INFORMATION model S26KN Pulp and paper diaphragm seals**

Select one character or set of characters from each category and specify complete catalog number.

<b>BASE MODEL</b> - 1 <sup>st</sup> to 5 <sup>th</sup> characters	S 2 6 K N	X	X	XX	X	X	X	X
Pulp and paper diaphragm seal								
<b>Transmitter Side of Connection</b> - 6 <sup>th</sup> character								
High pressure side		H						
<b>Size / Mounting connection</b> - 7 <sup>th</sup> character								
1 in. pulp and paper seal - sealing with gaskets to spud (NOT AVAILABLE WITH SENSOR G AND S)								U
1 1/2 in. pulp and paper seal - sealing with gasket to spud (NOT AVAILABLE WITH SENSOR S)								K
1 in. pulp and paper seal with 1 in. NPT male threaded connection (NOT AVAILABLE WITH SENSOR G)								W
1 1/2 in. pulp and paper seal with 1 1/2 in. NPT male threaded connection								Z
1 in. pulp and paper seal with G 1 in. A male threaded connection (NOT AVAILABLE WITH SENSOR G)								1
1 1/2 in. pulp and paper seal with G 1 1/2 in. A male threaded connection								2
1 in. pulp and paper seal with ball valve connection (NOT AVAILABLE WITH SENSOR G AND S and 266NDH)								Y
1 1/2 in. pulp and paper seal - sealing with gasket to M44 threaded spud (NOT AVAILABLE WITH SENSOR S)								V
<b>Diaphragm Material</b> - 8 <sup>th</sup> and 9 <sup>th</sup> characters								
AISI 316 L ss	(Note 1)							SL
Hastelloy C-276								HL
Diaflex (AISI with anti-abrasion treatment)	(Note 1)							FL
<b>Capillary Protection</b> - 10 <sup>th</sup> character								
Extension tube for direct mount seal								N
<b>Capillary Length m (Feet)</b> - 11 <sup>th</sup> character								
Direct-mount construction								1
<b>Fill Fluid</b> - 12 <sup>th</sup> character								
Silicone oil DC200 10 cSt								S
Mineral oil Esso Marcol 122 (FDA approved)	(Note 5)							W
<b>Clamp/Fittings</b> - 13 <sup>th</sup> character								
Not required								N
Weld-on spud and fixing screw for 1 in. pulp & paper seal connection	(Note 2)							C
Weld-on threaded spud for 1 1/2 in. pulp & paper seal connection	(Note 3)							D
Weld-on spud and fixing screws for 1 1/2 in. pulp & paper seal connection	(Note 4)							F

Note 1: Not available with connection code Y,

Note 2: Suitable ONLY for 1 in. size - sealing with gaskets code U

Note 3: Suitable ONLY for 1-1/2 in. size to M44 threaded spud - sealing with gaskets code V

Note 4: Suitable ONLY for 1-1/2 in. size - sealing with gaskets code K

# Model 266DDH Differential

## Model 266HDH Gauge

## Model 266NDH Absolute

### BASIC ORDERING INFORMATION model S26JN In-line diaphragm seals

Select one character or set of characters from each category and specify complete catalog number.

<b>BASE MODEL</b> - 1 <sup>st</sup> to 5 <sup>th</sup> characters	S 2 6 J N	X	X	XX	X	X	X
In-line diaphragm seal							
<b>Transmitter Side of Connection</b> - 6 <sup>th</sup> character		H					
High pressure side							
<b>Size / Mounting connection</b> - 7 <sup>th</sup> character							
DN 25 / 1 in.			A				
DN 40 / 1 1/2 in.			B				
DN 50 / 2 in.			C				
DN 80 / 3 in.			D				
<b>Diaphragm Material</b> - 8 <sup>th</sup> and 9 <sup>th</sup> characters							
AISI 316 L ss	NACE			SM			
Hastelloy C-276	NACE			HM			
<b>Capillary Protection</b> - 10 <sup>th</sup> character							
Extension tube for direct mount seal						N	
<b>Capillary Length m (Feet)</b> - 11 <sup>th</sup> character							
Direct-mount construction							1
<b>Fill Fluid</b> - 12 <sup>th</sup> character							
Silicone oil DC200 10 cSt							S
Silicone oil Baysilone PD5 5 cSt							P
Inert oil - Galden G5 (Note 1)							N
Inert oil - Halocarbon 4.2 (Note 1)							D
Silicone oil DC704							G
Silicone polymer Syltherm XLT							C
Mineral oil Esso Marcol 122 (FDA approved) (Note 2)							W
Vegetable oil Neobee M-20 (FDA approved) (Note 2)							A
Glycerin-water 70% (FDA approved) (Note 2)							B

Note 1: Suitable for oxygen service  
 Note 2: Suitable for food application

Note 1: Not available with transmitter side of connection code L  
 Note 2: Not available with capillary protection code A, B  
 Note 3: Not available with capillary protection code N  
 Note 4: Suitable for oxygen service  
 Note 5: Suitable for food application

**BASIC ORDERING INFORMATION model S26VN Socket and saddle diaphragm seals**

Select one character or set of characters from each category and specify complete catalog number.

BASE MODEL - 1 <sup>st</sup> to 5 <sup>th</sup> characters	S	2	6	V	N	X	XX	X	X	X	X	X
Socket and saddle diaphragm seal												
<b>Transmitter Side of Connection - 6<sup>th</sup> character</b>												
High pressure side						H						
Low pressure side						L						
<b>Diaphragm Material - 7<sup>th</sup> and 8<sup>th</sup> characters</b>												
AISI 316 L ss						NACE	SM					
Hastelloy C-276						NACE	HM					
Hastelloy C-2000						NACE	MM					
Inconel 625						NACE	LM					
Tantalum							TM					
AISI 316 L ss gold plated						NACE	NM					
Superduplex ss (UNS S32750 to ASTM SA479)						NACE	EM					
<b>Capillary Protection - 9<sup>th</sup> character</b>												
AISI 316 L ss armour												A
AISI 316 L ss armour with PVC protective cover												B
Extension tube for direct mount seal (Note 1)												N

continued  
see next page

# Model 266DDH Differential

## Model 266HDH Gauge

## Model 266NDH Absolute

BASIC ORDERING INFORMATION model S26VN		S	2	V	N	X	X	X	X
<b>Capillary Length m (Feet) - 10<sup>th</sup> character</b>									
Direct-mount construction	(Note 2)					1			
1 (3)	(Note 3)					A			
1.5 (5)	(Note 3)					B			
2 (7)	(Note 3)					C			
2.5 (8)	(Note 3)					D			
3 (10)	(Note 3)					E			
3.5 (12)	(Note 3)					F			
4 (13)	(Note 3)					G			
4.5 (15)	(Note 3)					H			
5 (17)	(Note 3)					J			
<b>Fill Fluid - 11<sup>th</sup> character</b>									
Silicone oil DC200 10 cSt								S	
Silicone oil Baysilone PD5 5 cSt								P	
Inert oil - Galden G5	(Note 4)							N	
Inert oil - Halocarbon 4.2	(Note 4)							D	
Silicone oil DC704								G	
Silicone polymer Syltherm XLT								C	
Mineral oil Esso Marcol 122 (FDA approved)	(Note 5)							W	
Vegetable oil Neobee M-20 (FDA approved)	(Note 5)							A	
Glycerin-water 70% (FDA approved)	(Note 5)							B	
<b>Process Fitting Connections - 12<sup>th</sup> character</b>									
Not required									N
Saddle 2 in.									1
Saddle 2 1/2 in.									2
Saddle 3 in.									3
Saddle 4 in.									4
Saddle 5 in.									5
Saddle 6 in.									6
Socket 1/2 in.									A
Socket 3/4 in.									B
Socket 1 in.									C
Socket 1 1/2 in.									D
Socket 2 in.									E
<b>Gasket - 13<sup>th</sup> character</b>									
PTFE									2
Graphite									7

Note 1: Not available with transmitter side of connection code L  
 Note 2: Not available with capillary protection code A, B  
 Note 3: Not available with capillary protection code N  
 Note 4: Suitable for oxygen service  
 Note 5: Suitable for food application







# Contact us

## **ABB Ltd.**

### **Process Automation**

Howard Road  
St. Neots  
Cambridgeshire PE19 8EU  
UK

Tel: +44 (0)1480 475321

Fax: +44 (0)1480 217948

## **ABB Inc.**

### **Process Automation**

125 E. County Line Road  
Warminster  
PA 18974  
USA

Tel: +1 215 674 6000

Fax: +1 215 674 7183

## **ABB Automation Products GmbH**

### **Process Automation**

Schillerstr. 72  
32425 Minden  
Germany

Tel: +49 551 905 534

Fax: +49 551 905 555

## **ABB S.p.A.**

### **Process Automation**

Via Statale 113  
22016 Lenno (CO)  
Italy

Tel: +39 0344 58111

Fax: +39 0344 56278

[www.abb.com](http://www.abb.com)

## Note

We reserve the right to make technical changes or modify the contents of this document without prior notice. With regard to purchase orders, the agreed particulars shall prevail. ABB does not accept any responsibility whatsoever for potential errors or possible lack of information in this document.

We reserve all rights in this document and in the subject matter and illustrations contained therein. Any reproduction, disclosure to third parties or utilization of its contents - in whole or in parts - is forbidden without prior written consent of ABB.

Copyright© 2010 ABB

All rights reserved

3KXP200017R1001

™ Hastelloy C-276 is a Cabot Corporation trademark

™ Hastelloy C-2000 is an Haynes International trademark

™ Monel is an International Nickel Co. trademark

™ Viton is a Dupont de Nemour trademark

™ DC200 is a Dow Corning Corporation trademark

™ DC704 is a Dow Corning Corporation trademark

™ Galden is a Montefluos trademark

™ Halocarbon is a Halocarbon Products Co. trademark

™ Baysilone is a GE Bayer trademark

™ Neobee M-20 is a Stepan Company trademark

™ Esso Marcol 122 is a Esso Italiana trademark

™ Syltherm is a Dow Chemical Company trademark